

**A10**

**ACOS 6.0.7-P2  
Configuring ACOS Virtual  
Chassis Systems**

November, 2025

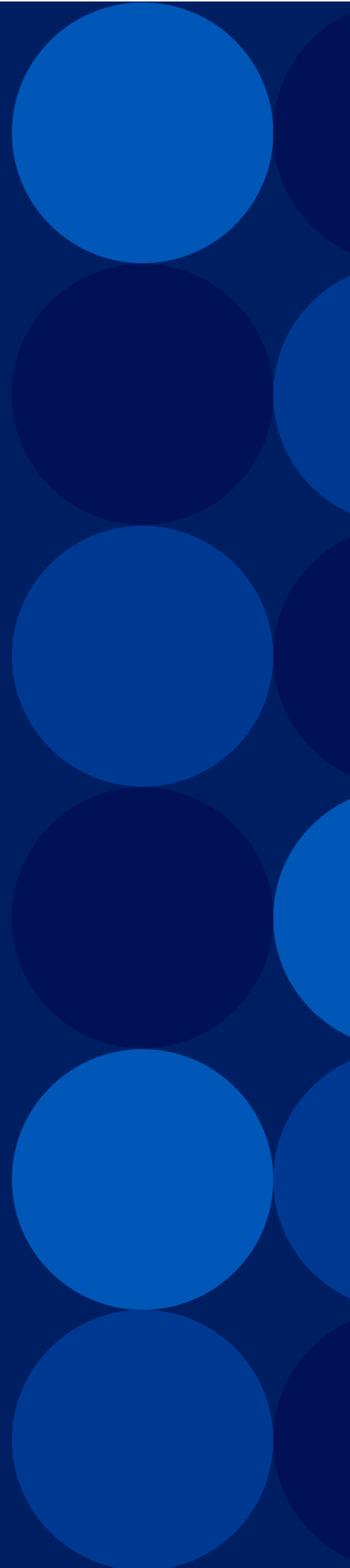

© 2025 A10 Networks, Inc All rights reserved.

Information in this document is subject to change without notice.

## PATENT PROTECTION

A10 Networks, Inc products are protected by patents in the U.S. and elsewhere. The following website is provided to satisfy the virtual patent marking provisions of various jurisdictions including the virtual patent marking provisions of the America Invents Act. A10 Networks, Inc products, including all Thunder Series products, are protected by one or more of U.S. patents and patents pending listed at:

[a10-virtual-patent-marking](#).

## TRADEMARKS

A10 Networks, Inc trademarks are listed at: [a10-trademarks](#)

## CONFIDENTIALITY

This document contains confidential materials proprietary to A10 Networks, Inc This document and information and ideas herein may not be disclosed, copied, reproduced or distributed to anyone outside A10 Networks, Inc without prior written consent of A10 Networks, Inc

## DISCLAIMER

This document does not create any express or implied warranty about A10 Networks, Inc or about its products or services, including but not limited to fitness for a particular use and non-infringement. A10 Networks, Inc has made reasonable efforts to verify that the information contained herein is accurate, but A10 Networks, Inc assumes no responsibility for its use. All information is provided "as-is." The product specifications and features described in this publication are based on the latest information available; however, specifications are subject to change without notice, and certain features may not be available upon initial product release. Contact A10 Networks, Inc for current information regarding its products or services. A10 Networks, Inc products and services are subject to A10 Networks, Inc standard terms and conditions.

## ENVIRONMENTAL CONSIDERATIONS

Some electronic components may possibly contain dangerous substances. For information on specific component types, please contact the manufacturer of that component. Always consult local authorities for regulations regarding proper disposal of electronic components in your area.

## FURTHER INFORMATION

For additional information about A10 products, terms and conditions of delivery, and pricing, contact your nearest A10 Networks, Inc location, which can be found by visiting [www.a10networks.com](http://www.a10networks.com).

# Table of Contents

<b>Getting Started</b> .....	<b>1</b>
Overview .....	2
aVCS Details .....	2
Virtual Chassis Management Interface (Floating IP Address) .....	4
aVCS Configuration Management .....	4
aVCS Software Version Management .....	4
aVCS Prerequisites .....	6
Layer 2 Connectivity .....	6
aVCS Image Location .....	6
vMaster Election .....	6
Understanding vMaster Election .....	7
aVCS Initial Deployment .....	7
VRRP-A Active/Standby Device Selection .....	7
aVCS and VRRP-A vMaster Selection .....	8
vMaster Election During Initial (First-Time) Deployment .....	8
Initial Virtual Chassis Deployment .....	9
vMaster Election for Initial Deployment - Same Priority and Boot Time .....	9
vMaster Election for Initial Deployment - Different Priorities, Same Boot Time .....	10
vMaster Election Using Dynamic Priority .....	11
vMaster Election and Heartbeat Messages .....	12
vMaster Election and Split Chassis .....	13
Forced vMaster Takeover .....	14
aVCS Configuration Management and Synchronization .....	15
aVCS Configuration Management .....	16
Automated Configuration Synchronization .....	17
Manual Configuration Synchronization .....	19
aVCS Software Image Synchronization .....	19
Customizing the Virtual Chassis .....	20

Changing the System Time in a Virtual Chassis .....	21
Configurable aVCS Prompts .....	21
Restoring the Default Prompt Display .....	21
<b>Deploying a Virtual Chassis .....</b>	<b>23</b>
Initial aVCS Deployment .....	24
Overview .....	24
Initial vMaster Configuration .....	25
Initial vBlade Configuration .....	26
First-Time Deployment Example .....	27
Topology and Commands .....	28
vMaster Initial Configuration Example - IPv4 .....	28
vBlade Initial Configuration Example - IPv4 .....	32
vMaster Initial Configuration Example - IPv6 .....	34
vBlade Initial Configuration Example - IPv6 .....	38
Forcing vMaster Takeover .....	41
Procedure .....	41
Temp-Priority Value .....	42
Determining a Device's aVCS ID .....	42
Viewing aVCS Information .....	44
CLI Configuration .....	44
GUI Configuration .....	44
aVCS CLI-Session Management .....	45
CLI Message for Commands That Affect Only the Local Device .....	45
Local Device .....	45
Message Example .....	46
Notes .....	46
Configuring aVCS Master Affinity to VRRP-A Active .....	48
Overview .....	48
Configuration Example .....	49
aVCS Master Affinity to VRRP-A Active and vMaster Takeover .....	50

Disabling Syncing of SNMP sysContact OID .....	50
vMaster Maintenance Mode .....	51
<b>Device Management .....</b>	<b>52</b>
Adding a Device to a Virtual Chassis .....	52
Overview .....	52
Procedure .....	54
Replacing a Device in a Virtual Chassis .....	55
<b>Configuration Synchronization without Reload .....</b>	<b>57</b>
Usage Summary .....	57
VRRP-A with aVCS Deployment Example .....	59
Commands on Device 1 .....	59
Commands on Device 2 .....	60
<b>Upgrading ACOS Devices with aVCS Deployment .....</b>	<b>62</b>
<b>Upgrading aVCS Cluster from a pre-ACOS 6.0.6 Release to ACOS 6.0.6 or Later .....</b>	<b>64</b>

# Getting Started

---

This section provides an overview of the Virtual Chassis System (aVCS).

The following topics are covered:

<a href="#">Overview</a> .....	2
<a href="#">aVCS Prerequisites</a> .....	6
<a href="#">vMaster Election</a> .....	6
<a href="#">aVCS Configuration Management and Synchronization</a> .....	15
<a href="#">aVCS Software Image Synchronization</a> .....	19
<a href="#">Customizing the Virtual Chassis</a> .....	20

## Overview

The following topics are covered:

<a href="#">aVCS Details</a> .....	2
<a href="#">Virtual Chassis Management Interface (Floating IP Address)</a> .....	4
<a href="#">aVCS Configuration Management</a> .....	4
<a href="#">aVCS Software Version Management</a> .....	4

## aVCS Details

ACOS Virtual Chassis System (aVCS) enables you to manage a cluster of ACOS devices like a single, virtual chassis. One ACOS device in the virtual chassis is the virtual master (vMaster). The other ACOS devices are virtual blades (vBlades) within the virtual chassis, and are managed by the vMaster. As a controller for the vBlades, the vMaster provides centralized storage of the entire ACOS device configuration. Any configuration changes from the vMaster are automatically propagated to the vBlades.

aVCS, as a management tool, provides high availability functionality on the ACOS device with the help of VRRP-A across multiple ACOS devices.

Depending on the ACOS series model, with the help of VRRP-A, aVCS can support a maximum 7 additional blades. aVCS requires that all devices in the same virtual switch have the same number of CPUs and are the same ACOS device model.

**CAUTION:**

If you use the `system-reset` command to restore an ACOS device to its factory default state, the command affects *all* ACOS devices in the virtual chassis. The command erases any saved configuration profiles (including startup-config), as well as system files such as SSL certificates and keys, aFlex policies, black/white lists, and system logs. The management IP address and admin-configured admin and enable passwords are also removed. The only workaround is to reload the system from a saved configuration or configure the device once again.

---

**NOTE:** Before performing a `system-reset`, always create a system backup of the ACOS device to allow you to be able to restore the ACOS device from the backup when necessary.

---

aVCS elects a single device within the virtual chassis as the vMaster for the chassis. The vMaster provides a single point of control for all devices in the virtual chassis, as shown in [Figure 1](#).

Figure 1 : vMaster - Control Point for all Devices

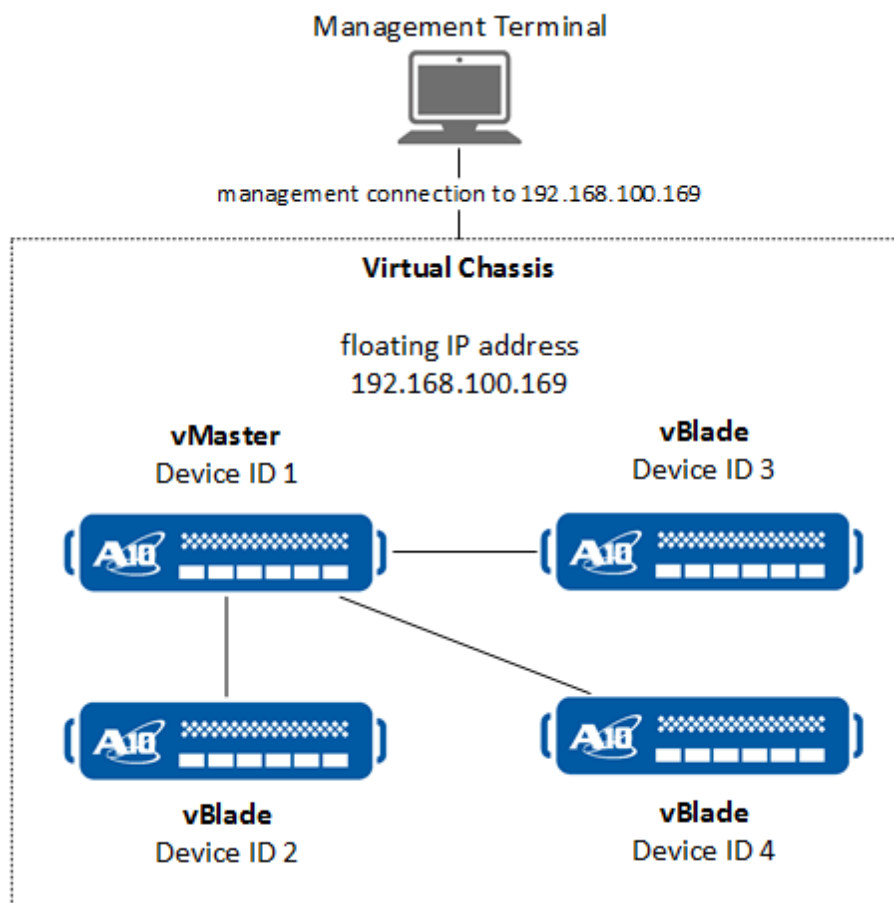

In addition to individual device management and aVCS configurations, the vMaster can also take care of the following operations on vBlades:

- Synchronize configurations
- Synchronize certificates

- Synchronize keys
- Synchronize aFlex policies
- Synchronize black/white lists
- Synchronize code versions

## Virtual Chassis Management Interface (Floating IP Address)

---

The virtual chassis has a floating IP address. The virtual chassis' floating IP address is the management address for the chassis. To manage a virtual chassis, establish a management connection (for example, CLI or GUI) to the floating IP address.

When you connect to the virtual chassis' management IP address, the connection goes to the vMaster. You can make configuration changes only on the vMaster. The vMaster automatically sends the changes to the vBlades.

If necessary, you can change the context of the management session to a specific vBlade. To change the management context to the vBlade, use the `vcs admin-session-connect` command. The management session will change from the vMaster to the specified vBlade. For more information about the `vcs admin-session-connect` command, see *Command Line Reference Guide*.

---

**NOTE:** For more information, see [aVCS CLI-Session Management](#).

---

## aVCS Configuration Management

---

When you make a configuration change on the vMaster, the change is sent to the running-config on each vBlade.

---

**NOTE:** For more information, see [aVCS Configuration Management and Synchronization](#).

---

## aVCS Software Version Management

---

The vMaster also ensures that each device in the virtual chassis is running the same software version.

**NOTE:** For more information, see [aVCS Software Image Synchronization](#).

## aVCS Prerequisites

aVCS has the following prerequisite requirements:

- [Layer 2 Connectivity](#)
- [aVCS Image Location](#)

## Layer 2 Connectivity

aVCS uses IP multicast. All ACOS devices in an aVCS virtual chassis must be in the same Layer 2 broadcast domain.

aVCS can operate across different geographic regions provided latency is low. VRRP-A session synchronization will be the gating factor in terms of latency.

**NOTE:** When using aVCS with VRRP-A high availability, the aVCS management address (virtual chassis' floating IP address) should not be the same as a VRRP-A floating IP address of the VRID.

## aVCS Image Location

The aVCS-capable image must be installed in the same image area on each device. For example, install the image in the primary image area of the hard disk or solid state drive (SSD) on each device.

## vMaster Election

This section contains information about vMaster election in a virtual chassis and the factors that help determine which device becomes the vMaster.

The following topics are covered:

<a href="#">Understanding vMaster Election</a> .....	7
<a href="#">vMaster Election During Initial (First-Time) Deployment</a> .....	8
<a href="#">vMaster Election Using Dynamic Priority</a> .....	11

<a href="#">vMaster Election and Heartbeat Messages</a> .....	12
<a href="#">vMaster Election and Split Chassis</a> .....	13
<a href="#">Forced vMaster Takeover</a> .....	14

## Understanding vMaster Election

---

The devices in a virtual chassis use a vMaster election process to elect the vMaster for the virtual chassis.

The following topics are covered:

<a href="#">aVCS Initial Deployment</a> .....	7
<a href="#">VRRP-A Active/Standby Device Selection</a> .....	7
<a href="#">aVCS and VRRP-A vMaster Selection</a> .....	8

To understand when a vMaster will take over as the Active device, it is necessary to understand different configuration scenarios that impact vMaster selection for aVCS, for VRRP-A, and for aVCS with VRRP-A:

### aVCS Initial Deployment

For initial configuration, each ACOS device in the virtual chassis is assigned an aVCS device ID and aVCS priority. An ACOS device becomes the vMaster if it has the highest configured aVCS priority among all the other ACOS devices in the virtual chassis. If all ACOS devices in the aVCS configuration have the same aVCS priority, then the ACOS device with the highest device ID will become the vMaster. In this configuration, each ACOS device will be a stand-alone device, without any active or standby pairs.

To avoid having to configure each individual ACOS device separately, it is recommended that you configure only one ACOS device that will serve as the vMaster then have the vMaster automatically configure the remaining ACOS devices in the virtual chassis.

### VRRP-A Active/Standby Device Selection

When VRRP-A is configured, the Active device selection is based on two factors, weight and priority, before electing an Active device that will have several Standby devices ready to take over that role. An ACOS device will become an Active or

Standby device depending on the weight or priority of that device. The weight of an ACOS device will always take precedence over the priority. If we have a higher weight but a lower priority, the ACOS device with the higher weight will be the Active. If the weight of the devices are equal, the ACOS device with the higher priority will become the Active ACOS device. If the weight and the priority of the devices are equal, the ACOS device with the lowest VRRP-A device ID will be the Active ACOS device.

As a ACOS device user, configure VRRP-A using VRRP-A failover templates and VRRP-A tracking options to adjust the weight (using failover templates) or priority (using global tracking options) of an ACOS device and elect an Active device.

---

**NOTE:** For more information, see *Configuring VRRP-A High Availability*.

---

## aVCS and VRRP-A vMaster Selection

When aVCS and VRRP-A are configured to work in conjunction, all ACOS devices will be able to process traffic as an Active/Standby pair, but these Active/Standby pairs will be configurable using a single ACOS device. The VRRP-A concept of having an Active device and a Standby device to process traffic will remain the same. However, with aVCS, you can configure the Active and Standby devices using a single ACOS device.

In summary, aVCS has its own configured priority and dynamic priority for electing the vMaster not for electing the Active or Standby device. Use the `show vcs statistics` command to display the configured and dynamic priority.

VRRP-A has its own weight and priority algorithm to determine which ACOS device is the Active or the Standby device, however, it does not elect the vMaster. Use the `show vrrp-a` command to display the weight and priority for the devices running VRRP-A. For details on how a failover occurs based on weight or priority using a template, refer to “Event Tracking for Weight or Priority” in *Configuring VRRP-A High Availability*. You can force a device to serve as a vMaster without dynamic election by temporarily assigning it a higher priority.

## vMaster Election During Initial (First-Time) Deployment

---

The following topics are covered:

[Initial Virtual Chassis Deployment](#) ..... 9

[vMaster Election for Initial Deployment - Same Priority and Boot Time](#) ..... 9

[vMaster Election for Initial Deployment - Different Priorities, Same Boot Time](#) 10

## Initial Virtual Chassis Deployment

For initial virtual chassis deployment, the vMaster is elected based on one of the following parameters:

- Priority – The device with the highest configured aVCS priority is elected to be the vMaster. If you boot one of the devices first and allow it to become the vMaster, the device remains the vMaster when the other devices join the virtual chassis, even if the configured priority is higher on another device. This is due to the *dynamic priority* value assigned by aVCS.

---

**NOTE:** For more information, see [Initial Virtual Chassis Deployment](#).

---

- Device ID – If all devices have the same configured priority, the device with the highest aVCS device ID is elected to be the vMaster.

---

**NOTE:** For more information, see [vMaster Election for Initial Deployment - Same Priority and Boot Time](#) and [vMaster Election for Initial Deployment - Different Priorities, Same Boot Time](#).

---

## vMaster Election for Initial Deployment - Same Priority and Boot Time

[Figure 2](#) illustrates vMaster selection in a virtual chassis where all devices have the same priority and are booted up at the same time. In this situation, the device with the highest device ID (Device 4) is elected as the vMaster.

Figure 2 : vMaster Election in Initial Deployment - Same Priority Value on each Device

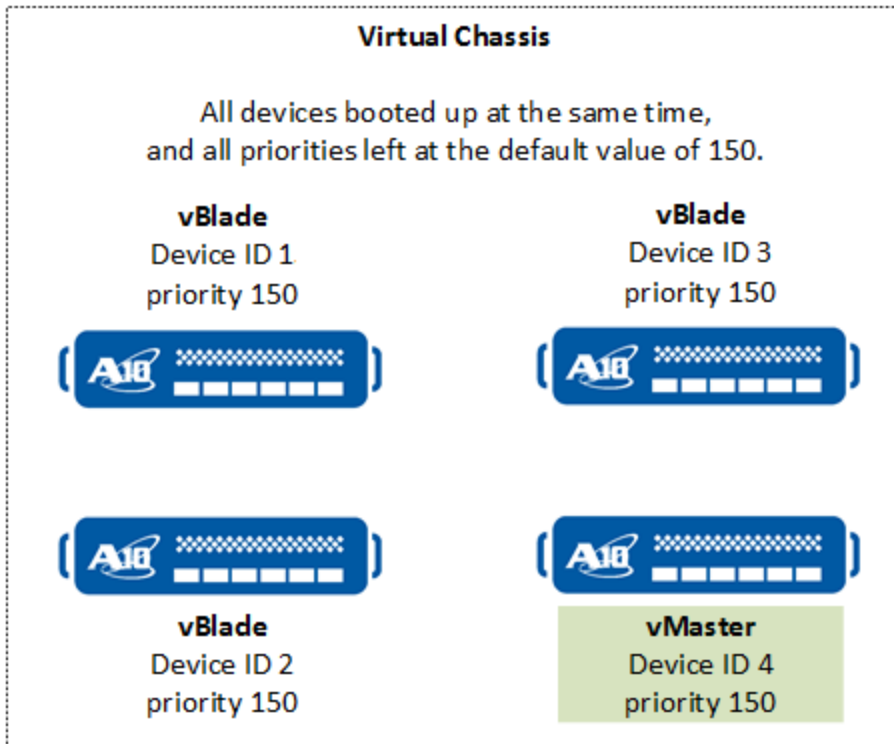

### vMaster Election for Initial Deployment - Different Priorities, Same Boot Time

[Figure 3](#) illustrates vMaster selection in a virtual chassis where each device has a different priority, and all devices are booted up at the same time. In this situation, the device with the highest priority (Device 4) is elected as the vMaster.

Figure 3 : vMaster Election in Initial Deployment - Different Priority Values Configured

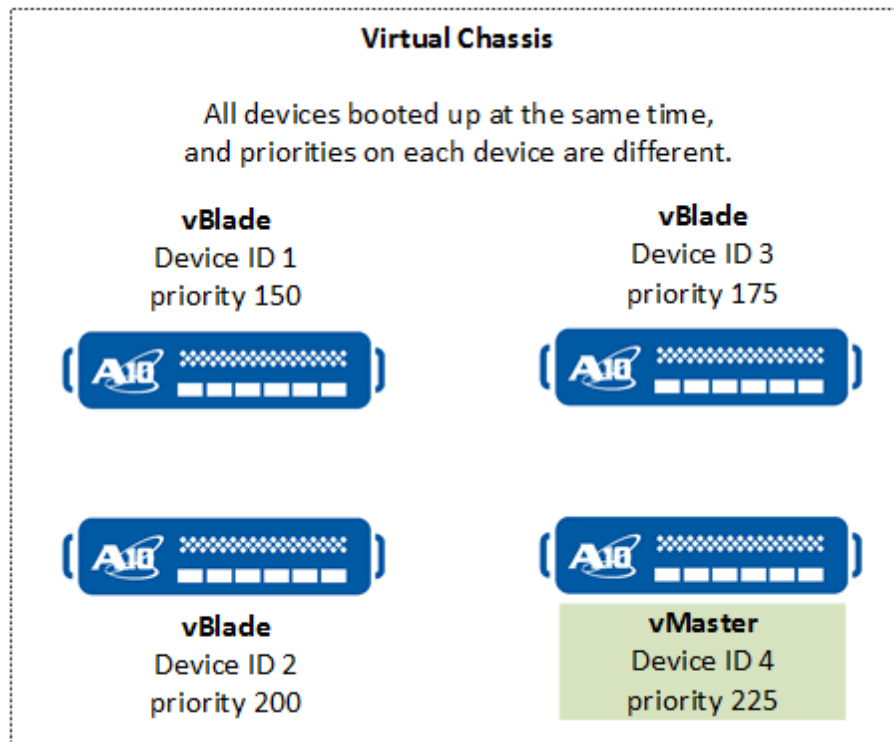

## vMaster Election Using Dynamic Priority

The configurable aVCS priority is a static value in each device's configuration. After a virtual chassis becomes active, another priority value, the dynamic priority, becomes the most important parameter when electing the vMaster. The device with the highest dynamic priority always becomes the vMaster.

The dynamic priority adds stability to the virtual chassis, by consistently using the same device as vMaster whenever possible. Once a device becomes vMaster, its dynamic priority ensures that it will remain the vMaster, even if another device has a higher configured priority. For example, if the vMaster becomes unavailable and a vBlade transitions to vMaster, the new vMaster remains in control even if the previous vMaster rejoins the virtual chassis.

The following [Figure 4](#) shows an example of how dynamic priority works. Device 3 was booted first, and even though other devices have higher priority values, dynamic priority keeps Device 3 as the vMaster.

Figure 4 : vMaster Election with Dynamic Priority

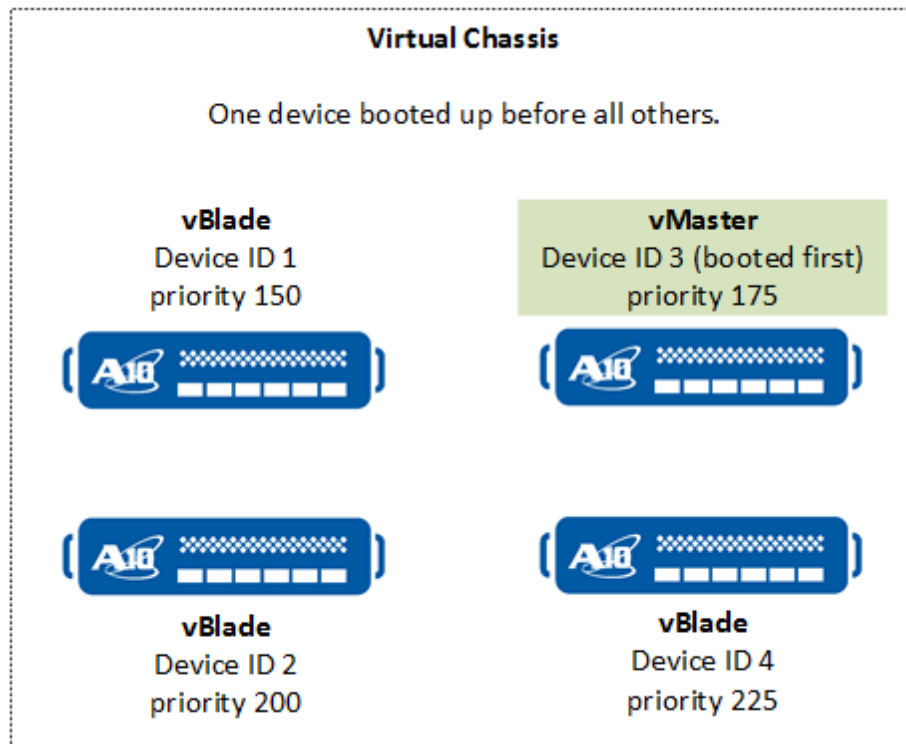

Dynamic priority is not configurable. However, you can force a vBlade to become the vMaster. (See [Forced vMaster Takeover](#).)

## vMaster Election and Heartbeat Messages

At regular intervals (the heartbeat time interval), the vMaster sends heartbeat messages to each of the vBlades, to inform them that the vMaster is still up, as shown in the [Figure 5](#).

Figure 5 : Heartbeat Messages

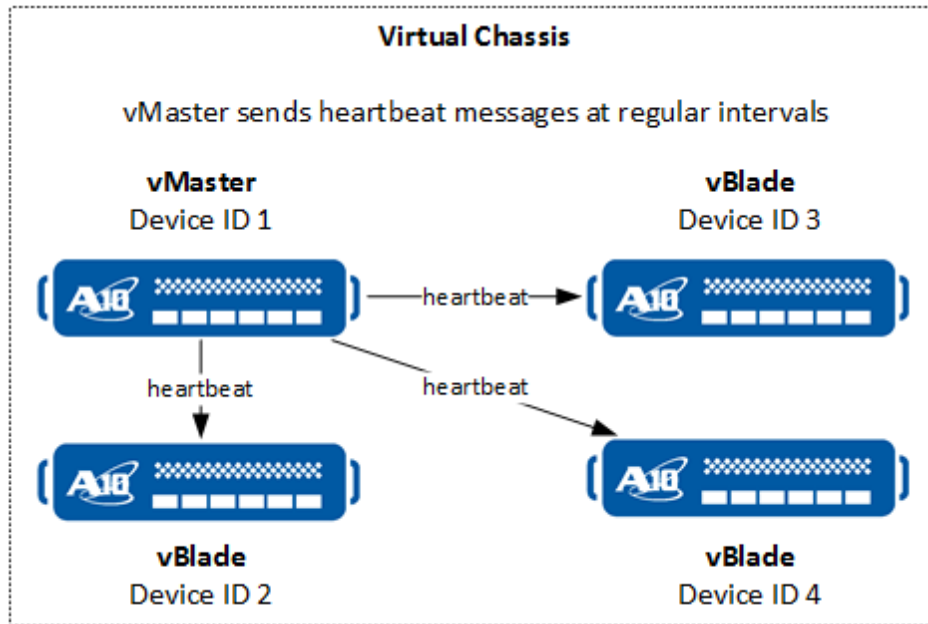

If a vBlade does not receive a heartbeat message within a specified amount of time (heartbeat dead interval), the vBlade changes its state from vBlade to vMaster-candidate, and engages in the vMaster election process with the other devices that are still up.

The default heartbeat time is 3 seconds. The default heartbeat dead interval is 10 seconds. Both parameters are configurable.

## vMaster Election and Split Chassis

If one or more vBlades lose contact with the vMaster, the vMaster remains in control for the vBlades that can still receive the vMaster's heartbeat messages. However, the other vBlades use the vMaster election process to elect a new vMaster. This results in two separate virtual chassis (a "split chassis"), as shown in the [Figure 6](#).

Figure 6 : vMaster Election - Split Chassis

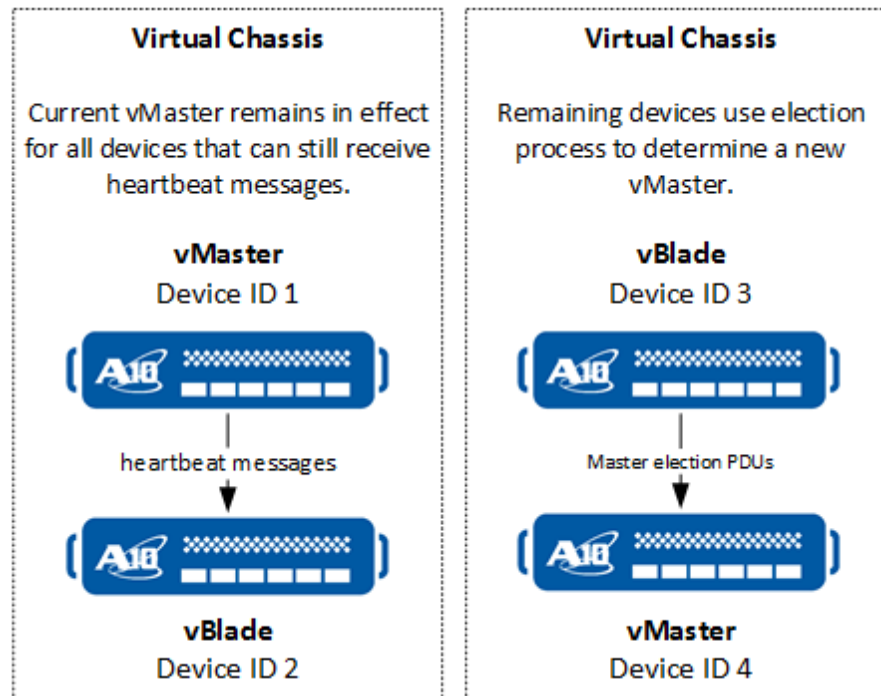

After the links among the disconnected devices are restored, the devices again use the vMaster election process to elect a vMaster. Generally, the vMaster that was in effect before the virtual chassis divided continues to be the vMaster after the virtual chassis is rejoined, based on the device's dynamic priority value (see [Initial Virtual Chassis Deployment](#)).

## Forced vMaster Takeover

You can force a vBlade to take over as vMaster, without changing the vMaster-election priority values configured on the devices. For example, you can force a vBlade to take over the vMaster role, without changing the aVCS profiles of any of the devices.

Figure 7 : Forced vMaster Takeover

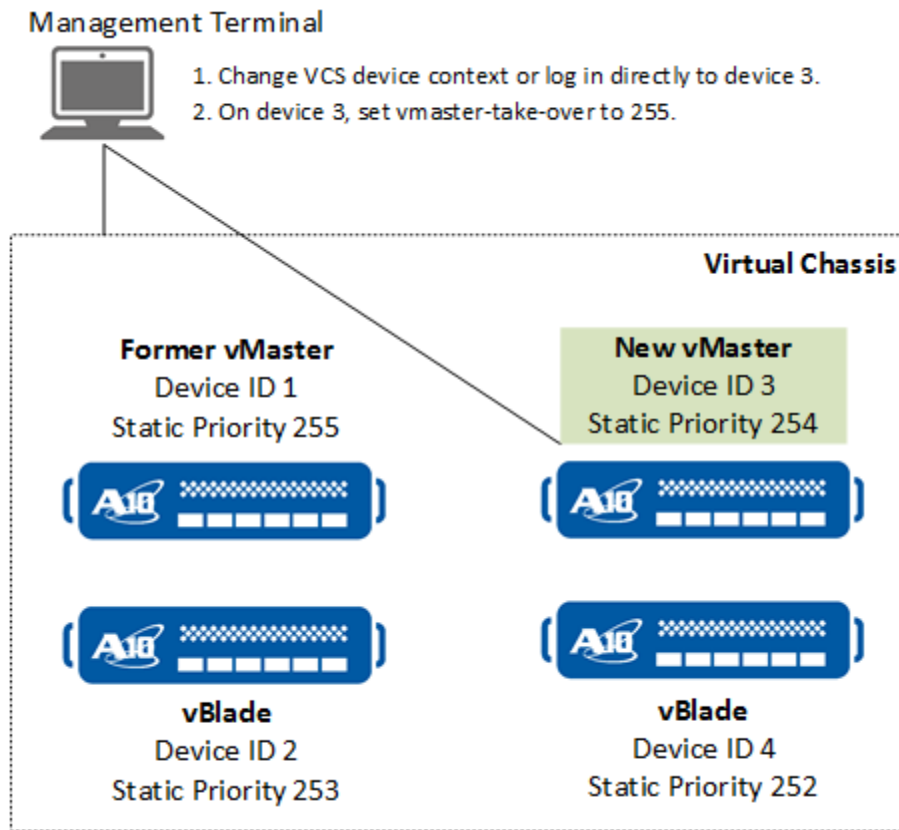

**NOTE:** For a configuration example, see [Forcing vMaster Takeover](#).

## aVCS Configuration Management and Synchronization

This section describes how configuration changes are handled within the virtual chassis.

The following topics are covered:

<a href="#">aVCS Configuration Management</a> .....	16
<a href="#">Automated Configuration Synchronization</a> .....	17
<a href="#">Manual Configuration Synchronization</a> .....	19

## aVCS Configuration Management

When you make a configuration change on the vMaster, the change is simultaneously propagated to the running configuration on each vBlade. For example ([Figure 8](#)), if you create a new SLB server “RS1” on the vMaster, the vMaster sends the server to the running configuration on each of the vBlades.

When the configuration on the vMaster is saved, the vMaster writes the contents of its running configuration to its startup configuration and performs the same action on each vBlade in the virtual chassis.

Figure 8 : aVCS Configuration Management

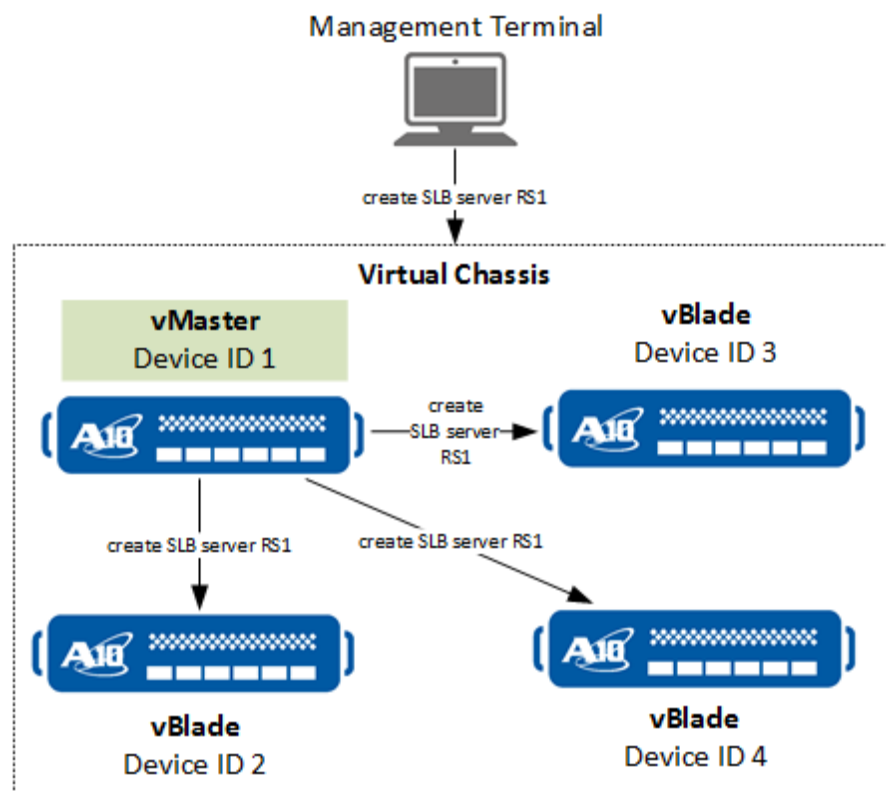

Once the virtual chassis is fully operational, all devices in the virtual chassis have exactly the same set of configuration profiles. This includes the startup configuration and any custom configuration profiles.

## Automated Configuration Synchronization

aVCS automatically synchronizes configuration information within the virtual chassis. Configuration changes are synchronized in real-time as they occur.

**NOTE:** aVCS configuration synchronization is not supported on the chassis platform. The configuration must be manually replicated on all devices.

All configuration changes are synchronized, even changes to device-specific parameters such as hostnames and IP addresses. aVCS configuration synchronization ensures that each device in the virtual chassis has a complete set of configuration information for itself and for each of the other devices. For example, configuration synchronization ensures that each device has the complete aVCS configuration for the virtual chassis ([Figure 9](#)).

Figure 9 : aVCS Device-Specific Parameters

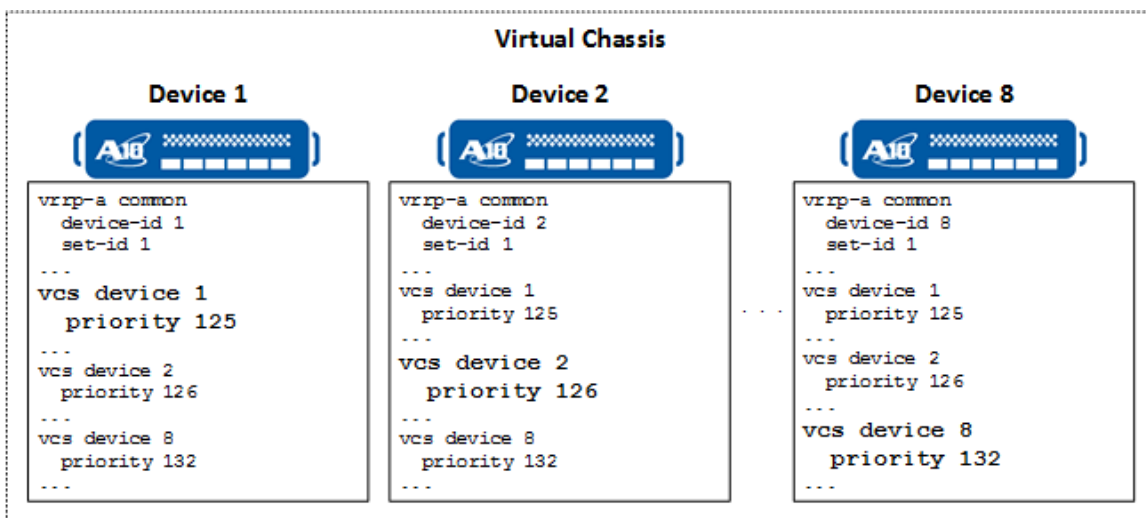

In this example, the device-specific portions of the configuration are shown in enlarged text bold type for each device.

**NOTE:** For brevity, some commands are omitted from the illustration. For example, in a working configuration, the `vcs enable` command normally would appear in the configuration for each device, under the `vrmp-a` commands, and the `enable` command would appear among the aVCS commands for each device.

Common parameters, such as SLB parameters, are shared by all devices in the virtual chassis and do not have a device ID ([Figure 10](#)).

Figure 10 : Common Parameters

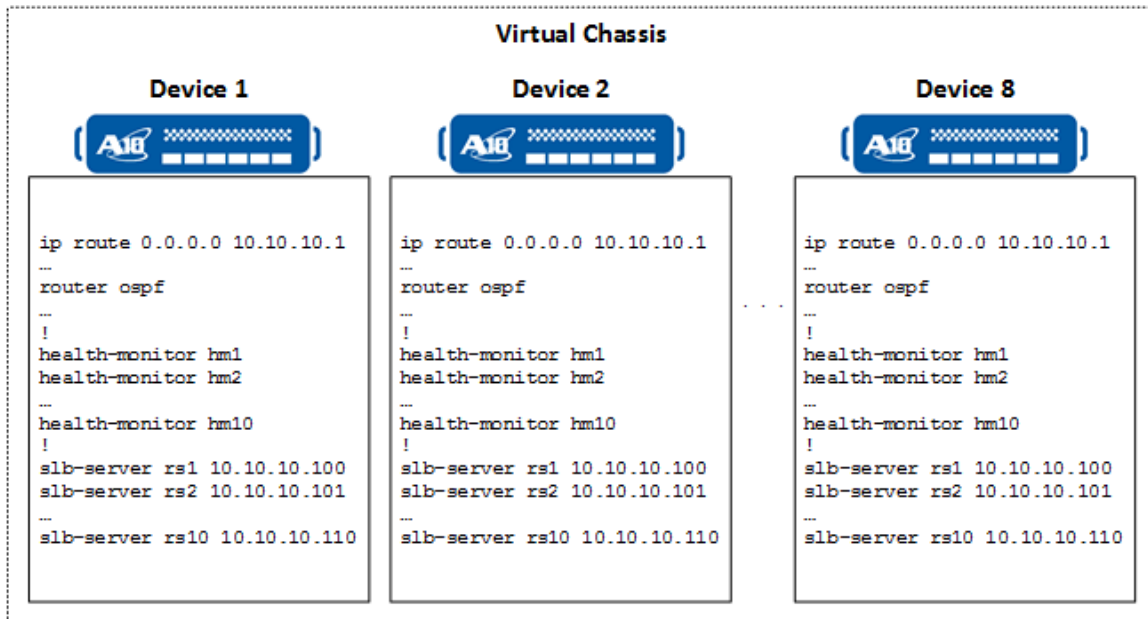

Interface parameters are unique to each device and include the aVCS device number ([Figure 11](#)).

Figure 11 : Interface Parameters

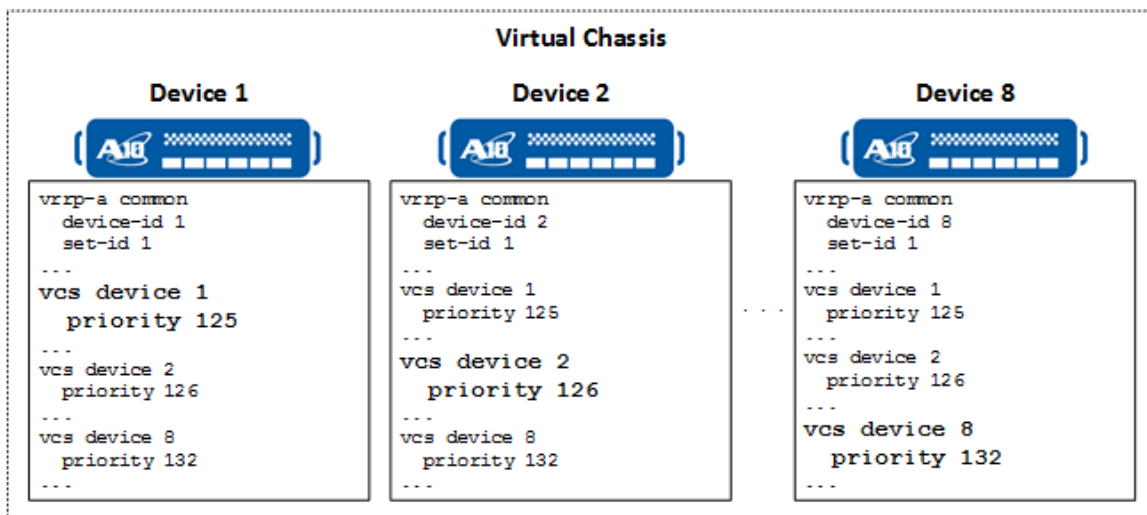

This example shows the configuration for each device's management IP address and an Ethernet interface. VLANs, Virtual Ethernet (VE) interfaces, and trunks also include the aVCS device ID.

## Manual Configuration Synchronization

---

Optionally, you can manually synchronize the VRRP-A configuration to specific devices. For more information on manual synchronization using VRRP-A, refer to “Manually Synchronizing the Configuration” in *Configuring VRRP-A High Availability*.

## aVCS Software Image Synchronization

In addition to the configuration repository, each device in the virtual chassis also has a software image repository. When a new or rebooted device joins the virtual chassis as a vBlade, the device compares its running software image version with the version running on the vMaster. If the version on the vMaster is newer, the vBlade downloads the image from the vMaster, then reboots to place the image into effect.

When a vBlade upgrades in this way, the new image replaces the older image, in the same image area. For example, if the vBlade boots the older image from the primary image area on the hard drive, the upgrade image downloaded from the vMaster replaces the image in the primary image area.

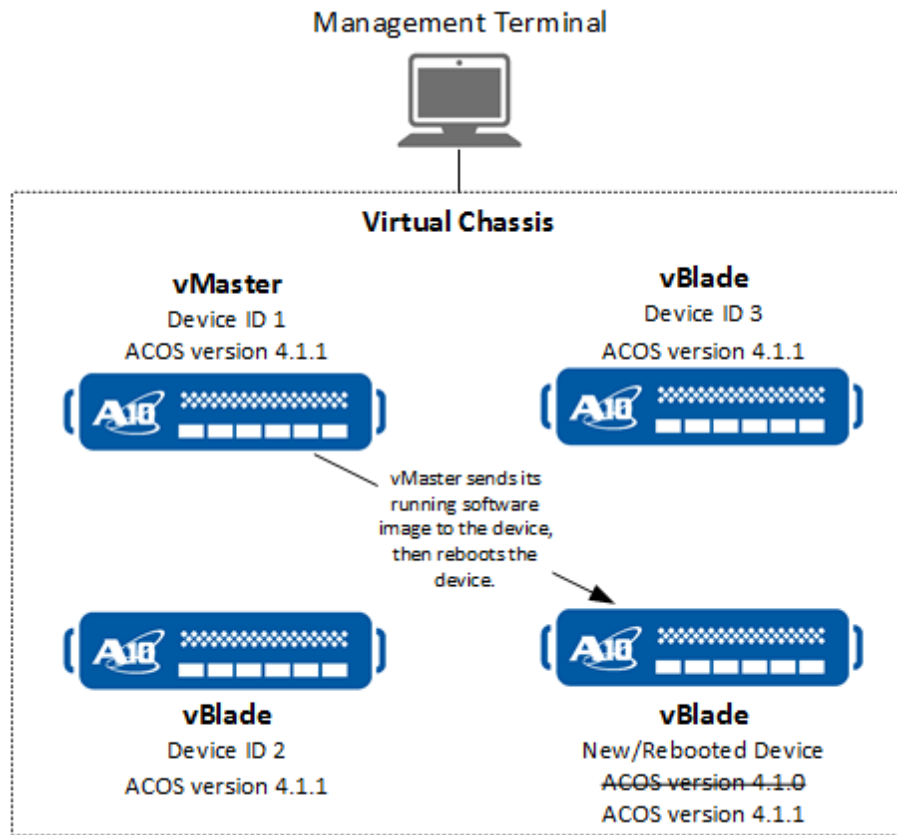

**NOTE:** When the web GUI image is upgraded on the vMaster, it gets synchronized to all vBlades.

## Customizing the Virtual Chassis

This section contains information for customizing items related to aVCS configuration.

The following topics are covered:

<a href="#">Changing the System Time in a Virtual Chassis</a> .....	21
<a href="#">Configurable aVCS Prompts</a> .....	21
<a href="#">Restoring the Default Prompt Display</a> .....	21

## Changing the System Time in a Virtual Chassis

---

If you need to set or change the system time on a vBlade in a virtual chassis, make sure to make the change on the vMaster, not directly on the vBlade.

This is especially important if you need to set the time *ahead* on the vBlade. In this case, if you set the time ahead directly on a vBlade, that device leaves, then rejoins the virtual chassis, and the change does not take effect.

## Configurable aVCS Prompts

---

The CLI prompt can be configured to reflect the aVCS chassis device ID and status.

To explicitly enable display of information items in the CLI prompt, use the following command at the global configuration level of the CLI:

```
terminal prompt info-item-list
```

The *info-item-list* can contain one or more of the following values:

- **vcs-status** [**chassis-device-id**] – Enables display of the aVCS status of the device.

The **chassis-device-id** option enables display of the virtual chassis ID and device ID.

- **hostname** – Enables display of the ACOS hostname.
- **chassis-device-id** – Display aVCS device id in the prompt. For example, this can be **7/1**, where the number **7** indicates the chassis ID and **1** indicates the device ID within the aVCS set.

**NOTE:** The aVCS Chassis ID and the aVCS Device ID are configurable as part of the prompt if aVCS is running. The prompt that you specify will be synchronized and reflected on all the other devices in the aVCS set.

## Restoring the Default Prompt Display

---

To re-enable display of all the information items, use the `no terminal prompt` global configuration command.

The following command disables display of the aVCS status and hostname in the CLI prompt:

```
ACOS2-Active-vMaster[1/1] (config)# terminal prompt ha-status  
Active (config) #
```

The following command re-enables display of all the information items:

```
Active (config) # no terminal prompt  
ACOS2-Active-vMaster[1/1] (config) #
```

---

**NOTE:** For more information, see “VRRP-A / VCS Status in Command Prompt” in the *Command Line Interface Reference*.

---

# Deploying a Virtual Chassis

---

This section describes how to deploy aVCS.

The following topics are covered:

<a href="#">Initial aVCS Deployment</a> .....	24
<a href="#">Forcing vMaster Takeover</a> .....	41
<a href="#">Determining a Device's aVCS ID</a> .....	42
<a href="#">Viewing aVCS Information</a> .....	44
<a href="#">aVCS CLI-Session Management</a> .....	45

## Initial aVCS Deployment

This section describes how to deploy aVCS for the first time.

The following topics are covered:

<a href="#">Overview</a> .....	24
<a href="#">Initial vMaster Configuration</a> .....	25
<a href="#">Initial vBlade Configuration</a> .....	26
<a href="#">First-Time Deployment Example</a> .....	27

**CAUTION:**

Use this procedure only for first-time deployment of aVCS. If you are upgrading ACOS devices on which aVCS is already configured, see the *Upgrading in an aVCS Environment* section in the Release Notes.

## Overview

The following [Table 1](#) summarizes the steps in the procedure for initial aVCS deployment.

Table 1 : Summary of Steps for Initial aVCS Deployment

Step	Description and Documentation
1	Complete aVCS configuration on the device that will be the vMaster.  <b>NOTE:</b> For more information, see <a href="#">Initial vMaster Configuration</a> .
2	After completing aVCS configuration on the vMaster, enable aVCS on the vBlades, and configure aVCS-related parameters for the vBlades.  <b>NOTE:</b> For more information, see <a href="#">Initial vBlade Configuration</a> .
3	Reload aVCS on the vBlades. At this point, the vMaster synchronizes the configuration to the vBlades.

Table 1 : Summary of Steps for Initial aVCS Deployment

Step	Description and Documentation
	<p><b>NOTE:</b> This step is not required when deploying aVCS in the GUI; when aVCS is enabled the GUI automatically performs the system reload to synchronize configurations.</p>
4	<p>View the running-config on the vMaster and on the vBlades to verify that both the vMaster and vBlades configurations are synchronized.</p> <p>The steps above establishes the first-time base aVCS configuration synchronization between vMaster and vBlades. After this, subsequent configuration changes on the vMaster are automatically synchronized to the vBlades.</p>
5	If you plan to use Layer 3 virtualization, configure it on the vMaster.

## Initial vMaster Configuration

To configure the vMaster for the first time:

- Configure the basic system settings if not configured:
  - Management interface and default gateway
  - Hostname
  - Ethernet interfaces
  - VLANs
  - Routing
- Configure the following aVCS settings related to VRRP-A high availability:
  - Chassis ID – Assign each device to the same set (this is the VRRP-A set ID).
  - Device ID – Assign a unique device ID to each device (this is the VRRP-A device ID).
- Enable aVCS.
- Configure the floating IP address that will be used by the virtual chassis.

The floating IP address must be in the same subnet as the ACOS device's management IP address or one of the device's data interface IP addresses.

5. Configure aVCS device settings:

- vMaster-election interface – Ethernet interface(s) to use for vMaster election. Generally, these interfaces are connected to the other devices in the virtual chassis. The election interfaces for devices in an aVCS virtual chassis must be in the shared partition. Use of an L3V private partition's interface as an aVCS election interface is not supported.
- (Optional) vMaster-election priority – If you want a specific device to serve as the vMaster for the virtual chassis, set that device's aVCS priority to 255. You can leave the priority set to its default value on the other devices, which will become vBlades.

To allow aVCS to select the vMaster based on aVCS device ID, leave the vMaster-election priority on all devices unchanged.

---

**NOTE:** It is recommended not to disable any of the vMaster election interfaces. Doing so can interrupt communication between vMaster and vBlade, and cause the vBlade to reload.

---

See [vMaster Initial Configuration Example - IPv4](#) and [vMaster Initial Configuration Example - IPv6](#) for an example configuration.

## Initial vBlade Configuration

---

This section provides details for the initial vBlade configuration. You must perform these steps on each device that you want to be a vBlade in the virtual chassis.

1. Configure basic system settings:

- Management interface and default gateway
- Hostname
- Ethernet interfaces
- VLANs
- Routing

2. Configure the following aVCS settings related to VRRP-A high availability:
  - Chassis ID – Assign each device to the same set (this is the VRRP-A set ID).
  - Device ID – Assign a unique device ID to each device (this is the VRRP-A device ID).
3. Enable aVCS.
4. Configure aVCS device settings:
  - vMaster-election interface – Ethernet interface(s) to use for vMaster election. Generally, these are the interfaces connected to the other devices in the virtual chassis. The election interfaces for devices in an aVCS virtual chassis must be in the shared partition. Use of an L3V private partition's interface as an aVCS election interface is not supported.
  - (Optional) vMaster-election priority – If you want a specific device to serve as the vMaster for the virtual chassis, set that device's VCS priority to 255. You can leave the priority set to its default value on the other devices, which will become vBlades.

To allow an aVCS to select the vMaster based on an aVCS device ID, leave the vMaster-election priority on all devices unchanged.

**NOTE:** It is recommended not to disable any of the vMaster election interfaces. Doing so can interrupt communication between vMaster and vBlade, and cause the vBlade to reload.  
For an example configuration, see [vBlade Initial Configuration Example](#).

## First-Time Deployment Example

The following topics are covered:

<a href="#">Topology and Commands</a> .....	28
<a href="#">vMaster Initial Configuration Example - IPv4</a> .....	28
<a href="#">vBlade Initial Configuration Example - IPv4</a> .....	32
<a href="#">vMaster Initial Configuration Example - IPv6</a> .....	34
<a href="#">vBlade Initial Configuration Example - IPv6</a> .....	38

## Topology and Commands

The following are the topologies (IPv4 and IPv6) to deploy a virtual chassis containing two devices.

Figure 12 : Sample First-Time aVCS Deployment Topology - IPv4

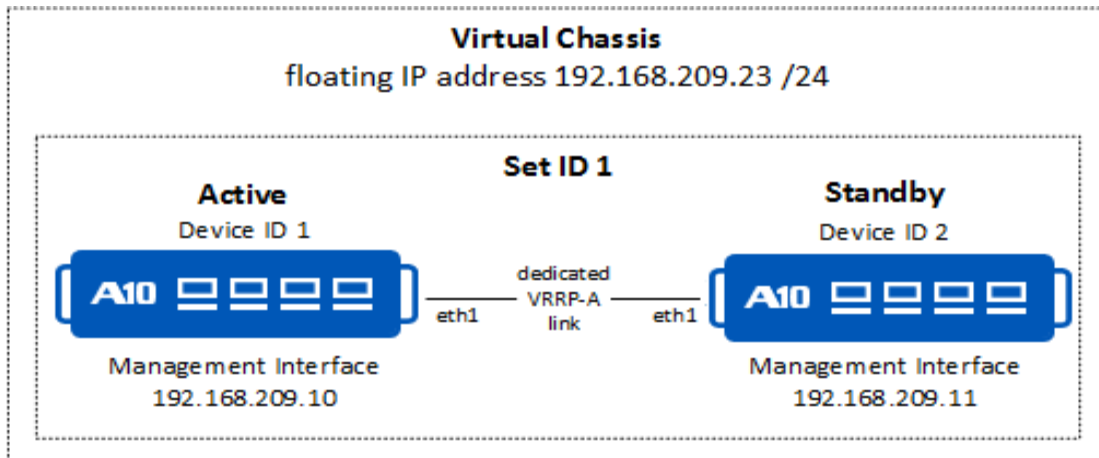
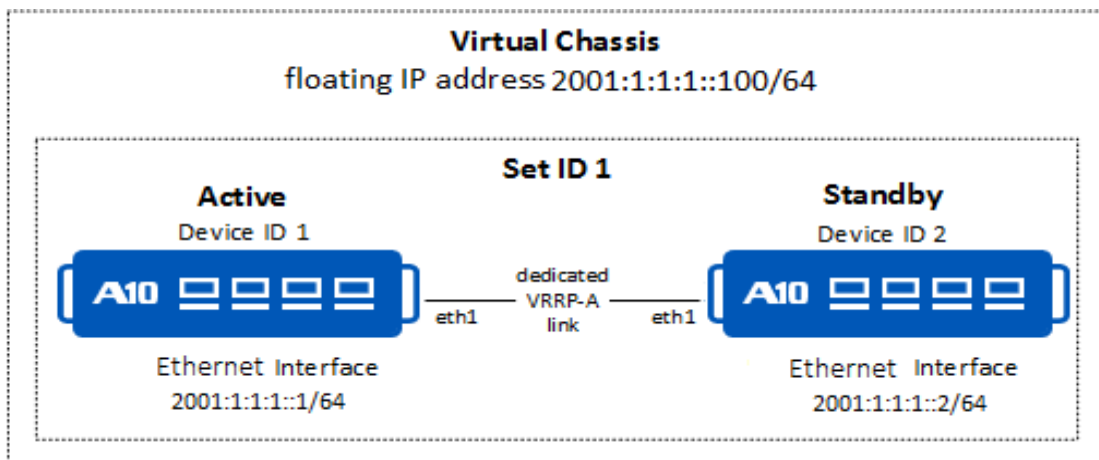

Figure 13 : Sample First-Time aVCS Deployment Topology - IPv6



**NOTE:** The configuration of basic system settings is not shown for simplicity.

### vMaster Initial Configuration Example - IPv4

This section provides an example of the initial configuration for the vMaster (IPv4).

### vMaster Initial Configuration Example Using the CLI - IPv4

1. Enable VRRP-A and configure the VRRP-A set ID and device ID:

```
ACOS# configure
ACOS(config)# vrrp-a common
ACOS(config-common)# set-id 1
ACOS(config-common)# device-id 1
ACOS(config-common)# exit
ACOS(config)#
```

2. Enable an aVCS:

```
ACOS(config)#vcs enable
ACOS(config:1)#
```

---

**NOTE:** The “:1” at the end of the prompt, indicating that aVCS enabled and you are on local device 1 (the vMaster). The device ID was set earlier using the `device-id` command under VRRP-A common configuration mode.

---

3. Configure the floating IP address for the virtual chassis:

```
ACOS(config:1)#vcs floating-ip 192.168.209.23 /24
```

4. Configure the VCS profile for the device:

```
ACOS(config:1)#vcs device 1
ACOS(config:1-device:1)# interfaces management
ACOS(config:1-device:1)# priority 125
ACOS(config:1-device:1)# enable
ACOS(config:1-device:1)# exit
ACOS(config:1)# vcs reload

System configuration has been modified. Save? [yes/no]:yes
Building configuration...
Write configuration to primary default startup-config
[OK]
Running configuration is saved
ACOS(config:1)#
```

## vMaster Initial Configuration Example Using the GUI - IPv4

1. Enable VRRP-A and configure the VRRP-A set ID and device ID.

- a. Hover over **System** in the menu bar, then select **VRRP-A**. Ensure **Global** is selected under the Settings Tab.
- b. Under the General Fields section, select **Enable** for the VRRP-A Enable field and configure the Device ID and Set ID by entering a device ID and set ID number in the respective fields.
- c. Click **OK**.

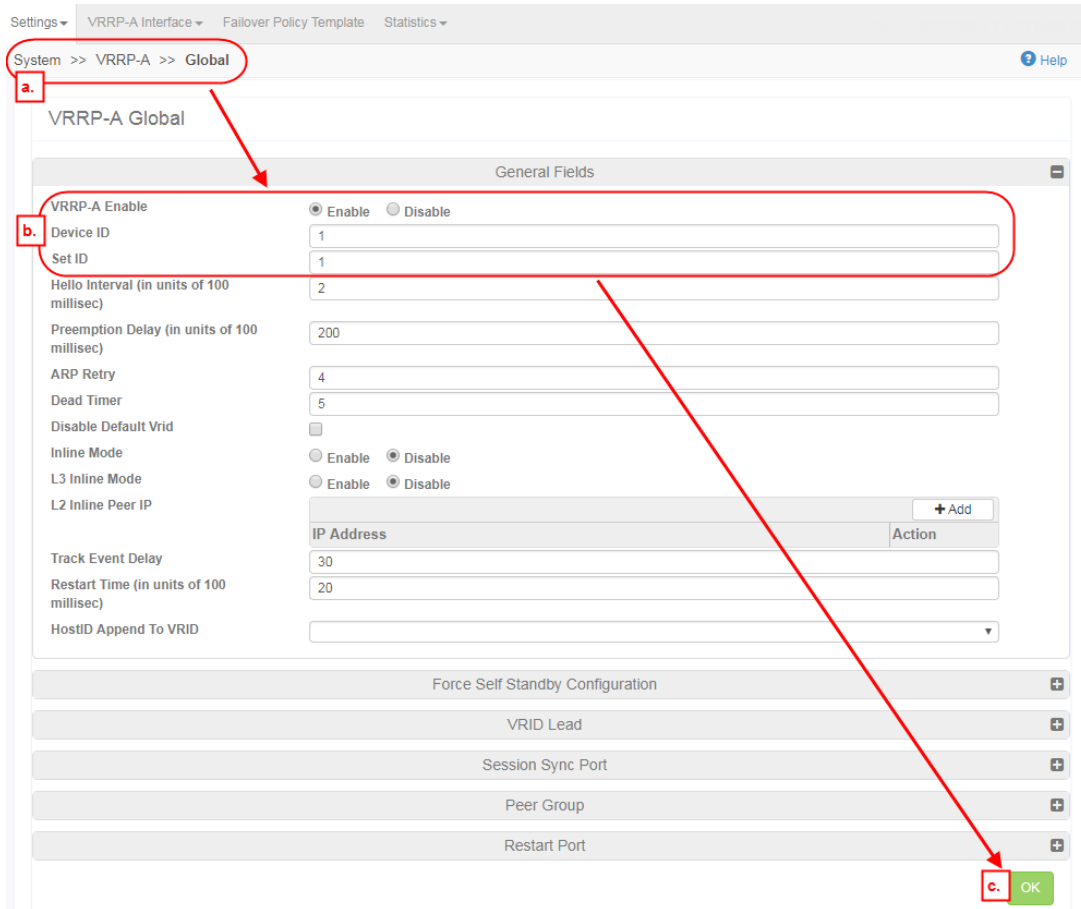

Settings ▾ VRRP-A Interface ▾ Failover Policy Template ▾ Statistics ▾

System >> VRRP-A >> Global Help

**a.**

VRRP-A Global

General Fields

**b.**

VRRP-A Enable  Enable  Disable

Device ID

Set ID

Hello Interval (in units of 100 millisc)

Preemption Delay (in units of 100 millisc)

ARP Retry

Dead Timer

Disable Default Vrid

Inline Mode  Enable  Disable

L3 Inline Mode  Enable  Disable

L2 Inline Peer IP

IP Address	Action
<input type="text" value="30"/>	<input type="button" value=""/>
<input type="text" value="20"/>	<input type="button" value=""/>

Track Event Delay

Restart Time (in units of 100 millisc)

HostID Append To VRID

Force Self Standby Configuration

VRID Lead

Session Sync Port

Peer Group

Restart Port

**c.**

## 2. Configure aVCS General Settings:

- a. Hover over **System** in the menu bar, then select **aVCS** and select **Enable** in the aVCS Enable field.
- b. Configure the management address for the virtual chassis.

Click **+Add** in the Floating IP Address section to add a Floating IP address row. In the IP Address Type field, select **IPv4** as the address type from the drop-down list, then enter **192.168.209.23** as the floating IP management address in the IP Address field, and enter **/24** as the subnet mask in the Netmask field.

c. Click **OK**.

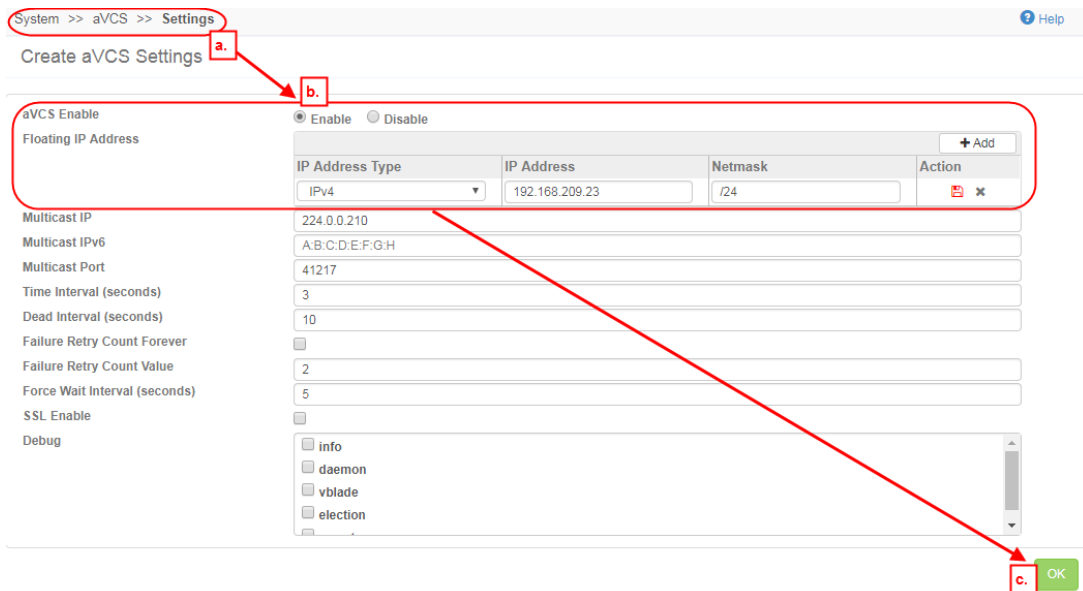

System >> aVCS >> Settings Help

Create aVCS Settings **a.**

aVCS Enable  Enable  Disable

Floating IP Address + Add

IP Address Type	IP Address	Netmask	Action
IPv4	192.168.209.23	/24	

Multicast IP: 224.0.0.210

Multicast IPv6: A:B:C:D:E:F:G:H

Multicast Port: 41217

Time Interval (seconds): 3

Dead Interval (seconds): 10

Failure Retry Count Forever:

Failure Retry Count Value: 2

Force Wait Interval (seconds): 5

SSL Enable:

Debug:  info  daemon  vblade  election

**c.** OK

3. Configure the aVCS device settings:

- a. From the **System > aVCS > Settings**, select the **Device** tab.
- b. Click **New Device**.
- c. In the Device field, specify the device ID.
- d. In the Priority field, specify the priority.
- e. Select **Enable** in the Enable field.
- f. Select **Enable** in the Management field.
- g. Click **Submit**.

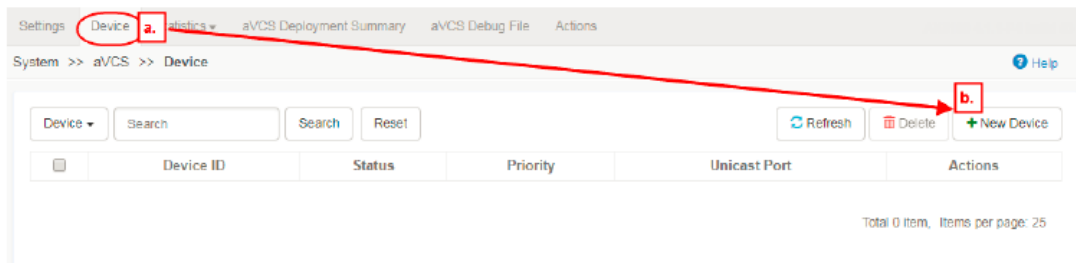
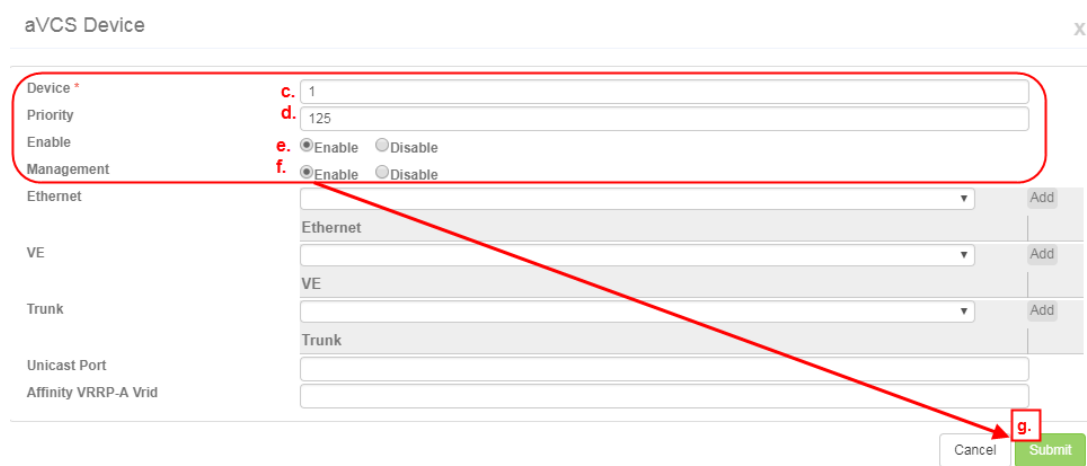
## vBlade Initial Configuration Example - IPv4

This section provides an initial configuration example for the vBlade. If your configuration contains multiple vBlades, this procedure should be repeated on each device.

### vBlade Initial Configuration Example Using the CLI - IPv4

```
ACOS-2# configure
ACOS-2(config)# vrrp-a common
ACOS-2(config-common)# set-id 1
ACOS-2(config-common)# device-id 2
ACOS-2(config-common)# exit
ACOS-2(config)# vcs enable
ACOS-2(config:2)# vcs floating-ip 192.168.209.23 /24
ACOS-2(config:2)# vcs device 2
ACOS-2(config:2-device:2)# interfaces management
```

```
ACOS-2(config:2-device:2)# priority 125
ACOS-2(config:2-device:2)# enable
ACOS-2(config:2-device:2)# exit
ACOS-2(config:2)# vcs reload

System configuration has been modified. Save? [yes/no]:yes
Building configuration...
Write configuration to primary default startup-config
[OK]
Running configuration is saved
ACOS-2(config:2)#
```

### vBlade Initial Configuration Example Using the GUI - IPv4

1. Enable VRRP-A and configure the VRRP-A set ID and device ID.
  - a. Hover over **System** in the menu bar, then select **VRRP-A**. Ensure **Global** is selected under the Settings Tab.
  - b. Under the General Fields section, select **Enable** for the VRRP-A Enable field and configure the Device ID and Set ID by entering a device ID and set ID number in the respective fields.
  - c. Click **OK**.
2. Configure aVCS General Settings:
  - a. Hover over **System** in the menu bar, then select **aVCS** and select **Enable** in the aVCS Enable field.
  - b. Configure the management address for the virtual chassis.

Click **+Add** in the Floating IP Address section to add a Floating IP address row. In the IP Address Type field, select **IPv4** as the address type from the drop-down list, then enter 192.168.209.23 as the floating IP management address in the IP Address field, and enter /24 as the subnet mask in the Netmask field.
  - c. Click **OK**.
3. Configure the aVCS device settings:
  - a. From the **System > aVCS > Settings**, select the **Device** tab.
  - b. Click **New Device**.

- c. In the Device field, specify the device ID.
  - d. In the Priority field, specify the priority.
  - e. Select **Enable** in the Enable field.
  - f. Select **Enable** in the Management field.
  - g. Click **Submit**.
4. Reload the device:
    - a. From the **System > aVCS > Device**, select the **Actions** tab.
    - b. In the Reload Option drop-down list, select **Reload** and click **Apply**.

Repeat this procedure for each device.

## vMaster Initial Configuration Example - IPv6

The VCS IPv6 cluster can be made available in the following ways:

- **Option 1** - Interfaces must be configured with global IPv6 address and multicast IPv6 address must be configured as site-local (**FFXE::**), where X can be 0 to F.
- **Option 2** - Interfaces must be configured with site-local (**FEC0::**) and multicast IPv6 address must be configured as site-local (**FFX5::**).

This section provides an example of an initial configuration for the vMaster and vBlade using Option 1. Option 2 is similar to Option 1, where the site-local address is used on both interface and multicast IPv6 address instead of global address.

**NOTE:** aVCS does not have a default multicast IPv6 address.

## vMaster Initial Configuration Example Using the CLI - IPv6

1. Enable VRRP-A and configure the VRRP-A set ID and device ID:

```
ACOS# configure
ACOS(config)# vrrp-a common
ACOS(config-common)# set-id 1
ACOS(config-common)# device-id 1
ACOS(config-common)# exit
ACOS(config)#
```

2. Enable an aVCS:

```
ACOS(config)#vcs enable
ACOS(config:1)#
```

---

**NOTE:** The “:1” at the end of the prompt, indicating that aVCS enabled and you are on local device 1 (the vMaster). The device ID was set earlier using the `device-id` command under VRRP-A common configuration mode.

---

3. Configure the multicast IPv6 address for the virtual chassis:

```
ACOS(config:1)#vcs multicast-ipv6 ff0e::100
```

4. Configure the VCS profile for the device:

```
ACOS(config:1)#vcs device 1
ACOS(config:1-device:1)# interfaces ethernet 1
ACOS(config:1-device:1)# priority 110
ACOS(config:1-device:1)# enable
ACOS(config:1-device:1)# exit

ACOS(config:1)# interface ethernet 1
ACOS(config-if:ethernet:1)# enable
ACOS(config-if:ethernet:1)# ipv6 address 2001:1:1:1::1/64
ACOS(config-if:ethernet:1)# ipv6 enable
ACOS(config-if:ethernet:1)# exit
ACOS(config:1)# vcs reload

System configuration has been modified. Save? [yes/no]:yes
Building configuration...
Write configuration to primary default startup-config
[OK]
Running configuration is saved
```

### vMaster Initial Configuration Example Using the GUI - IPv6

1. Enable VRRP-A and configure the VRRP-A set ID and device ID.
  - a. Hover over **System** in the menu bar, then select **VRRP-A**. Ensure **Global** is selected under the Settings Tab.

- b. Under the General Fields section, select **Enable** for the VRRP-A Enable field and configure the Device ID and Set ID by entering a device ID and set ID number in the respective fields.
- c. Click **OK**.

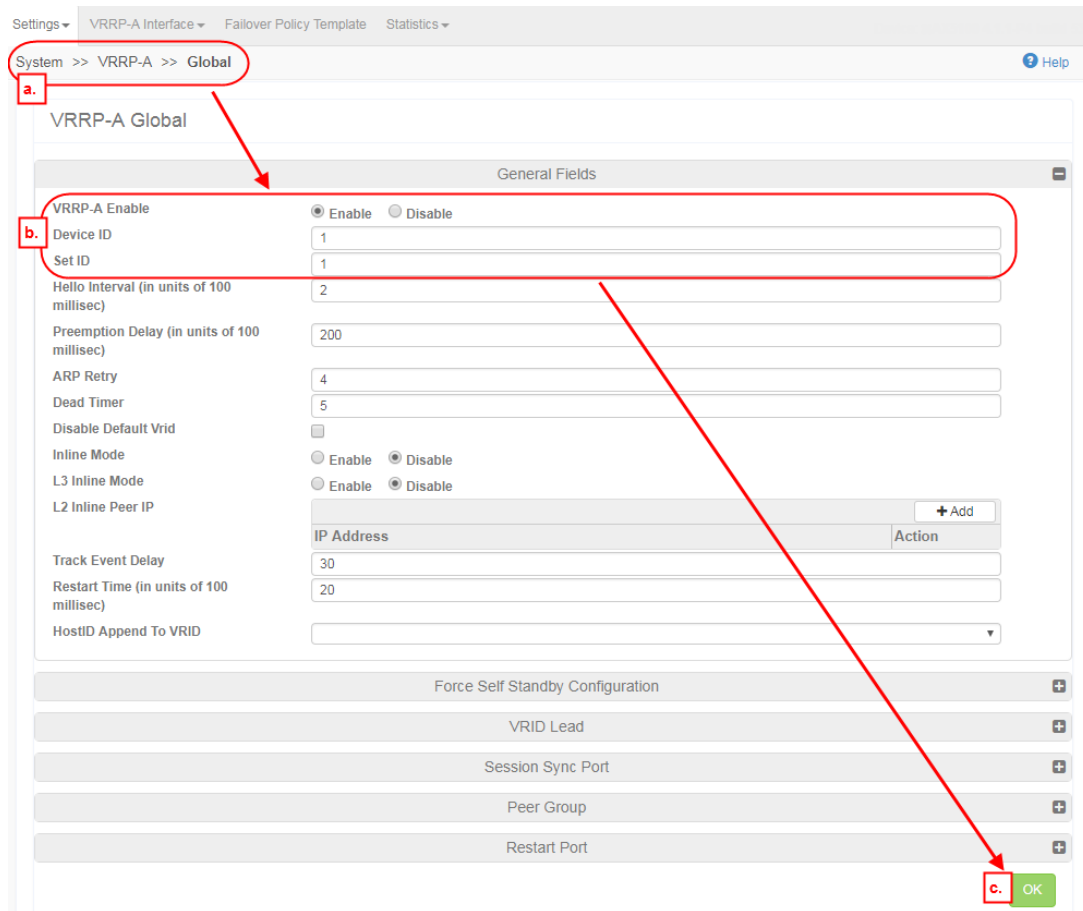

Settings ▾ VRRP-A Interface ▾ Failover Policy Template ▾ Statistics ▾

System >> VRRP-A >> Global Help

**a.**

VRRP-A Global

General Fields

VRRP-A Enable  Enable  Disable

**b.** Device ID

Set ID

Hello Interval (in units of 100 millisecond)

Preemption Delay (in units of 100 millisecond)

ARP Retry

Dead Timer

Disable Default Vrid

Inline Mode  Enable  Disable

L3 Inline Mode  Enable  Disable

L2 Inline Peer IP

Track Event Delay

Restart Time (in units of 100 millisecond)

HostID Append To VRID

Force Self Standby Configuration

VRID Lead

Session Sync Port

Peer Group

Restart Port

**c.**

## 2. Configure aVCS General Settings:

- a. Hover over **System** in the menu bar, then select **aVCS** and select **Enable** in the aVCS Enable field.
- b. Configure the management address for the virtual chassis.

Click **+Add** in the Floating IP Address section to add a Floating IP address row. In the IP Address Type field, select **IPv6** as the address type from the drop-down list, then enter `2001:1:1:1::1` as the floating IP management

address in the IP Address field, and enter /64 as the subnet mask in the Netmask field.

- c. In the Multicast IPv6 field, enter the multicast IPv6 address as ff03::100, and in the Multicast Port field, enter 41216.
- d. Click **OK**.

3. Configure the aVCS device settings:

- a. From the **System > aVCS > Settings**, select the **Device** tab.
- b. Click **New Device**.
- c. In the Device field, specify the device ID.
- d. In the Priority field, specify the priority.
- e. Select **Enable** in the Enable field.
- f. Select **Enable** in the Management field.
- g. Click **Submit**.

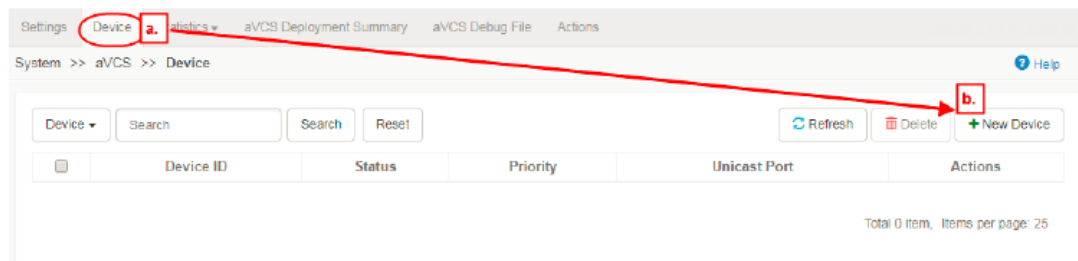

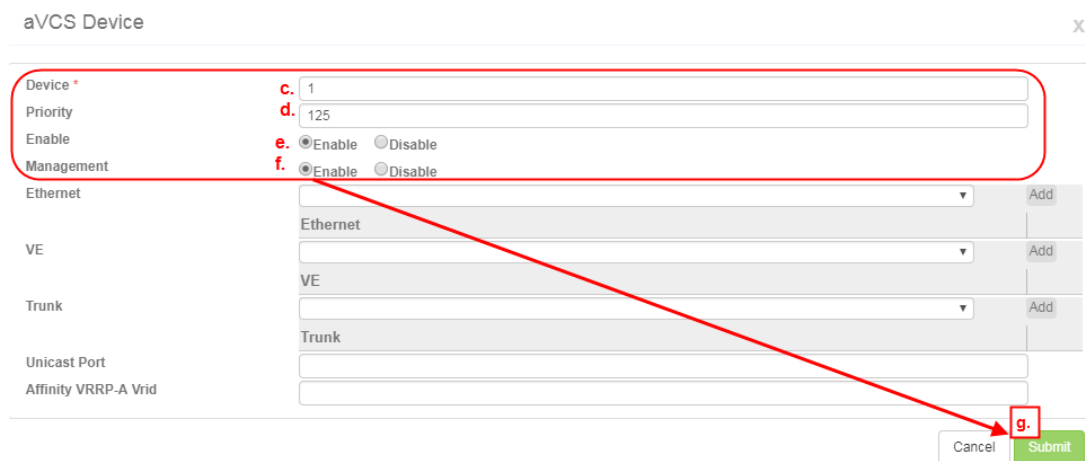

aVCS Device x

Device *	<input type="text" value="1"/>	<b>c.</b>
Priority	<input type="text" value="125"/>	<b>d.</b>
Enable	<input checked="" type="radio"/> Enable <input type="radio"/> Disable	<b>e.</b>
Management	<input checked="" type="radio"/> Enable <input type="radio"/> Disable	<b>f.</b>
Ethernet	<input type="text" value="Ethernet"/>	<input type="button" value="Add"/>
VE	<input type="text" value="VE"/>	<input type="button" value="Add"/>
Trunk	<input type="text" value="Trunk"/>	<input type="button" value="Add"/>
Unicast Port	<input type="text"/>	
Affinity VRRP-A Vrid	<input type="text"/>	

**g.**

## vBlade Initial Configuration Example - IPv6

This section provides an initial configuration example for the vBlade (IPv6). If your configuration contains multiple vBlades, this procedure should be repeated on each device.

### vBlade Initial Configuration Example Using the CLI - IPv6

**NOTE:** In this example, the configuration is configured on Interface Ethernet, similarly it can be configured on the Interface Management.

```

ACOS-2# configure
ACOS-2 (config)# vrrp-a common
ACOS-2 (config-common)# set-id 1
ACOS-2 (config-common)# device-id 2
ACOS-2 (config-common) #exit
ACOS-2 (config)# vcs enable
ACOS-2 (config:2)# vcs device 2
ACOS-2 (config:2-device:2)# interfaces ethernet 1
ACOS-2 (config:2-device:2)# priority 110
ACOS-2 (config:2-device:2)# enable
ACOS-2 (config:2-device:2)# exit
ACOS-2 (config:2)# interface ethernet 1
ACOS-2 (config:2-if:ethernet:1)# enable
ACOS-2 (config:2-if:ethernet:1)# ipv6 address 2001:1:1:1::2/64
ACOS-2 (config:2-if:ethernet:1)# ipv6 enable
ACOS-2 (config:2-if:ethernet:1)# exit

```

```

ACOS-2(config:2)# vcs reload

System configuration has been modified. Save? [yes/no]:yes
Building configuration...
Write configuration to primary default startup-config
[OK]
Running configuration is saved

```

## Viewing aVCS Information

Use the following show command to view the aVCS information:

```

ACOS-vMaster[2/1]#show vcs summary
aVCS Chassis:
VCS Configuration-Sync Enabled:           Yes
VCS Database-distribution Enabled:       No
Chassis ID:                               12
Unicast Election port:                   41473
Multicast IP:                             ff0e::100
Multicast Port:                           41473
Version:                                  6.0.5.b51
Current Discover mode:                    Multicast

Members (* means local device) (C:cfg-sync | D:db-sync | B:both):
ID  State          PriorityIP:Port          Location
-----
-----
1   vMaster(C) (*) 110      2001:1:1:1::1:41216    Local
2   vBlade(C)      100      2001:1:1:1::2:41216    Remote
Total: 2

```

## vBlade Initial Configuration Example Using the GUI - IPv6

1. Enable VRRP-A and configure the VRRP-A set ID and device ID.
  - a. Hover over **System** in the menu bar, then select **VRRP-A**. Ensure **Global** is selected under the Settings Tab.
  - b. Under the General Fields section, select **Enable** for the VRRP-A Enable field and configure the Device ID and Set ID by entering a device ID and set ID

number in the respective fields.

c. Click **OK**.

## 2. Configure aVCS General Settings:

a. Hover over **System** in the menu bar, then select **aVCS** and select **Enable** in the aVCS Enable field.

b. Configure the management address for the virtual chassis.

Click **+Add** in the Floating IP Address section to add a Floating IP address row. In the IP Address Type field, select **IPv6** as the address type from the drop-down list, then enter `2001:1:1:1::1` as the floating IP management address in the IP Address field, and enter `/64` as the subnet mask in the Netmask field.

c. In the Multicast IPv6 field, enter the multicast IPv6 address as `ff0e::100`, and in the Multicast Port field enter `41216`.

d. Click **OK**.

## 3. Configure the aVCS device settings:

a. From the **System > aVCS > Settings**, select the **Device** tab.

b. Click **New Device**.

c. In the Device field, specify the device ID.

d. In the Priority field, specify the priority.

e. Select **Enable** in the Enable field.

f. Select **Enable** in the Management field.

g. Click **Submit**.

## 4. Reload the device:

a. From the **System > aVCS > Device**, select the **Actions** tab.

b. In the Reload Option drop-down list, select **Reload** and click **Apply**.

Repeat this procedure for each device.

## Forcing vMaster Takeover

This topic describes how to force a vBlade to take over as the vMaster.

The following topics are covered:

<a href="#">Procedure</a> .....	41
<a href="#">Temp-Priority Value</a> .....	42

### Procedure

---

If you need to force a vBlade to take over the vMaster role:

1. Either change the management context to the vBlade or log directly onto the vBlade.

To change the management context to the vBlade, use the `vcs admin-session-connect` command. For more information about the `vcs admin-session-connect` command, see *Command Line Reference Guide*. For example, to change management context to the vBlade device 2:

```
vcs admin-session-connect device 2
```

2. After you have changed the management context to the vBlade, or logged on directly to the vBlade, use the `vcs vmaster-take-over` command. For more information about the `vcs vmaster-take-over` command, see *Command Line Reference Guide*. For example:

```
vcs vmaster-take-over 215
```

You are required to specify a temp-priority value (215 in this example). Unless you use this command on more than one vBlade, it does not matter which value within the range 1-255 you specify. (See [Temp-Priority Value](#)).

For more information about the commands, see *Command Line Reference Guide*.

## Temp-Priority Value

---

This command does not change the configured aVCS priority on the vBlade. The command only temporarily overrides the configured priority.

If you enter this command on only one vBlade, you can specify any value within the valid range (1-255). The takeover occurs regardless of priority settings on the current vMaster.

If you enter the `vcs vmaster-take-over` command on more than one vBlade, the device on which you enter the highest *temp-priority* value becomes the vMaster.

If you enter the same *temp-priority* value on more than one vBlade, the same parameters used for initial vMaster election are used to select the new vMaster:

- The device with the highest configured aVCS priority is selected. (This is the priority configured by the `priority` command at the configuration level for the aVCS device.)
- If there is a tie (more than one of the devices has the same highest configured aVCS priority), then the device with the highest device ID is selected.

In either case, the new vMaster is selected from among only the vBlades on which you enter the `vcs vmaster-take-over` command.

For more information about the `vcs vmaster-take-over` command, see *Command Line Reference Guide*.

## Determining a Device's aVCS ID

When you log onto the virtual chassis or onto an individual device in the chassis, the device's aVCS ID is not apparent, unless you modified the device's hostname to indicate the device ID.

To determine a device's VCS ID, use the `show vcs summary` command. The device you are logged onto is indicated with an asterisk in the State column of the Members section. For more information about the `show vcs summary` command, see *Command Line Interface Reference Guide*.

- If you are logged directly onto a device through its management interface or a data interface, the asterisk indicates the device.
- If you are logged onto the floating IP address of the virtual chassis, the asterisk indicates the vMaster.

(This is true unless you changed the device context of the management session. In this case, you are logged onto the vBlade to which you changed the device context. See [Virtual Chassis Management Interface \(Floating IP Address\)](#).)

The following example indicates that the device you are logged onto is aVCS device 1, indicated by the asterisk for device ID 1 in the “Members” section of the output:

**NOTE:** This is a sample output in which the VCS discovery is Unicast. In the ACOS 6.0.x version, the Multicast IP is 224.0.1.210, whereas in the ACOS 5.2.x version, the Multicast IP is 224.0.0.210.

```
ACOS-vMaster[1/1]# show vcs summary

aVCS Chassis:
  VCS Configuration-Sync Enabled:      Yes
  VCS Database-distribution Enabled:   Yes
  Chassis ID:                          14
  Unicast Election port:               41475
  Multicast IP:                        224.0.1.210
  Multicast Port:                      41474
  Version:                             6.0.5.b51
  Current Discover mode:               Unicast
Members (* means local device) (C:cfg-sync | D:db-sync | B:both):
ID  State          PriorityIP:Port          Location
-----
----
1   vBlade(B)      100    192.168.216.201:41216  Remote
2   vBlade(B)      100    192.168.216.202:41216  Remote
3   vMaster(B) (*) 100    192.168.216.203:41216  Local
Total: 3
```

In the GUI, you can view this information in the main header. Look for this section in the header:

vMaster(\*) : 192.168.216.201 ▼ Device Context : 1 ▼

The Device Context field shows that you are currently working on device 1 in the chassis. In addition, the field on the left indicates that this device (the local device, indicated by the asterisk) is the vMaster.

## Viewing aVCS Information

The following topics are covered:

<a href="#">CLI Configuration</a> .....	44
<a href="#">GUI Configuration</a> .....	44

## CLI Configuration

Use the `show vcs summary` command to view global virtual chassis parameters and the current role (vMaster or vBlade) of each device in the virtual chassis:

Use the `show vcs images` command to view the installed aVCS-capable ACOS software image:

```
ACOS# show vcs images
Image Name                Type
aximage_6_0_7_78.tar.gz   hd_pri
aximage_5_2_1-p5_114.tar.gz hd_sec
-----
ext
```

For more information about the `show vcs summary` and `show vcs images` commands, see *Command Line Interface Reference Guide*.

## GUI Configuration

From the GUI, navigate to **System > aVCS > Settings**. Click on the **Statistics** tab, then select **aVCS Summary** from the drop-down list. The resulting page shows general VCS statistics and available aVCS-capable images on the device.

Also from the GUI, navigate to **System > aVCS > Settings**, then click on the **aVCS Deployment Summary** tab to view information about your virtual chassis deployment.

## aVCS CLI-Session Management

The following topics are covered:

<a href="#">CLI Message for Commands That Affect Only the Local Device</a>	45
<a href="#">Configuring aVCS Master Affinity to VRRP-A Active</a>	48
<a href="#">Disabling Syncing of SNMP sysContact OID</a>	50
<a href="#">vMaster Maintenance Mode</a>	51

## CLI Message for Commands That Affect Only the Local Device

This release provides an option that displays a message when you enter a configuration command that applies to only the local device. When this option is enabled, a message is displayed if you enter a configuration command that affects only the local device, and the command does not explicitly indicate the device.

The following topics are covered:

<a href="#">Local Device</a>	45
<a href="#">Message Example</a>	46
<a href="#">Notes</a>	46

**NOTE:** This enhancement is enabled by default and cannot be disabled.

### Local Device

The “local device” is the device your CLI session is on.

- If you log directly onto one of the devices in the virtual chassis, that device is the local device. For example, if you log on through the management IP address of a vBlade, that vBlade is the local device.

- If you change the device context to another ACOS device, that device becomes the local device.
- If you log onto the virtual chassis' floating IP address, the vMaster is the local device.

## Message Example

The following command sets an aging time for learned MAC entries:

```
ACOS(config)# mac-age-time 444  
This operation applied to device 1
```

This type of configuration change is device-specific. However, the command does not specify the device ID to which to apply the configuration change. Therefore, the change is applied to the local device and the output message displays the device ID results. In this example, the local device is device 1 in the aVCS virtual chassis.

The message is not necessary if you explicitly specify the device, and therefore is not displayed:

```
ACOS(config)# device-context 2  
ACOS(config)# mac-age-time 444 device 2
```

## Notes

- For commands that access the configuration level for a specific configuration item, the message is displayed only for the command that accesses the configuration level. For example:

```
ACOS(config)# interface ethernet 2  
This operation applied to device 1  
ACOS(config-if:ethernet1/2)# ip address 1.1.1.1 /24  
ACOS(config-if:ethernet1/2)#
```

The message is not displayed after the `ip address` command is entered, because the message is already displayed after the `interface ethernet 2` command is entered.

The same is true for commands at the configuration level for a routing protocol. The message is displayed only for the command that accesses the configuration level for the protocol.

- In most cases, the message also is displayed following `clear` commands for device-specific items. An exception is `clear` commands for routing information. The message is not displayed following these commands.
- The message is not displayed after `show` commands.

## Configuring aVCS Master Affinity to VRRP-A Active

The following topics are covered:

- [Overview](#) .....48
- [Configuration Example](#) .....49
- [aVCS Master Affinity to VRRP-A Active and vMaster Takeover](#) ..... 50

### Overview

Master affinity to VRRP-A Active enables the vMaster device in a virtual chassis to failover when the Active device in a VRRP-A VRID fails over to a Standby device. When the Standby device becomes Active, it will also act as the vMaster device in the virtual chassis ([Figure 14](#)).

Figure 14 : VCS Master Affinity to VRRP-A Active

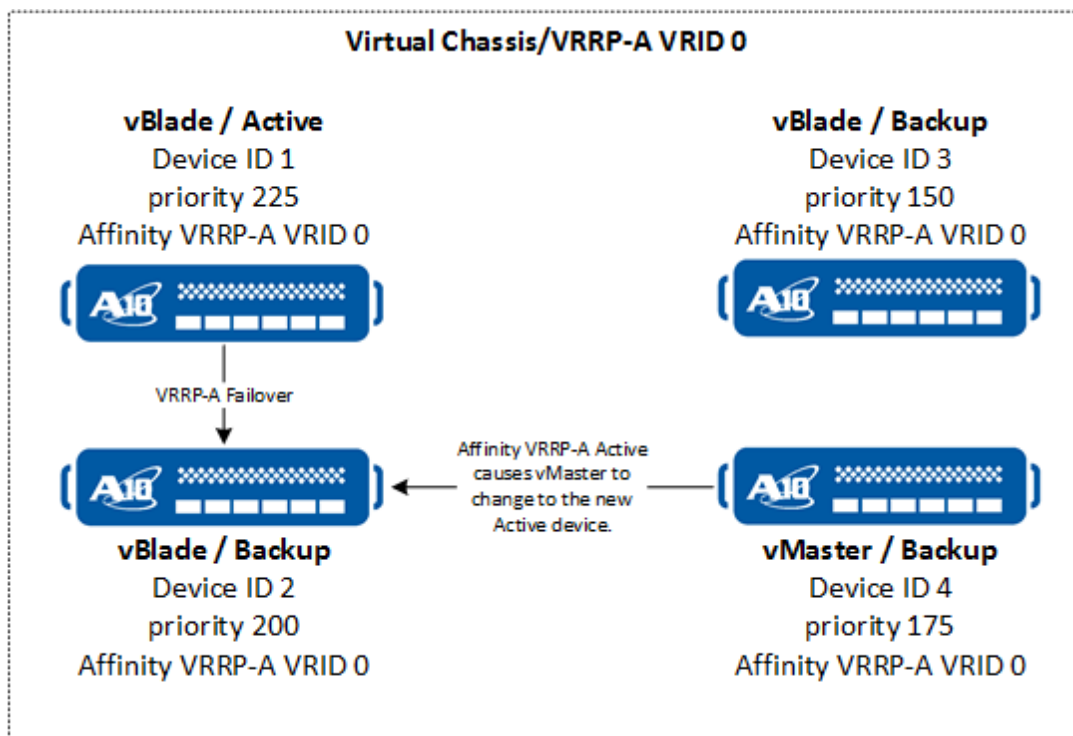

In this topology, device 1 is the Active device in the VRID. When it fails over, device 2 will become the Active device, as it has the next highest priority. Device 4, which is

currently the vMaster in the virtual chassis and is configured with VRID affinity, will follow the update in VRRP-A and switch to device 2 as the vMaster.

This ensures that the device assuming the master configuration also serves as the active data path. Configuring the VRID affinity causes the vMaster to stay with a selected VRID. This capability provides deterministic behavior on the location of the aVCS master and the unit processing traffic for a particular VRRP-A VRID. It also provides better control to effectively utilize available bandwidth and facilitates troubleshooting efforts.

## Configuration Example

To enable a vMaster failover to the Active device, the shared partition is configured to follow the Active device on a specified VRID (device running VRRP-A). On each device that is part of the aVCS cluster, including the Active device, issue the `affinity-vrrp-a-vrid` command. For more information, see the `vcs device` command in *Command Line Reference Guide*.

The following example snippets configure VRID affinity for four devices in a virtual chassis, based on the example topology in [Overview](#):

---

**NOTE:** The `affinity-vrrp-a-vrid` must be explicitly configured on all devices for which you want to enable this feature, and the VRID must also be the same for all devices.

---

```
!  
...  
vcs device 1  
  priority 225  
  enable  
  affinity-vrrp-a-vrid 0  
!  
vcs device 2  
  priority 200  
  enable  
  affinity-vrrp-a-vrid 0  
!  
vcs device 3  
  priority 150  
  enable
```

```
affinity-vrrp-a-vrid 0
vcs device 4
  priority 175
  enable
  affinity-vrrp-a-vrid 0

!
vcs local-device 1
...
```

## aVCS Master Affinity to VRRP-A Active and vMaster Takeover

VRID affinity and forced vMaster takeover ([Forced vMaster Takeover](#)) cannot be used together; you will see the following message if you try to configure vMaster takeover with VRID affinity configured:

```
Take over vMastership: VCS: vmaster take over is not allowed in affinity
vrid state
```

Once VRID affinity is configured, the vMaster will continue to follow the active device in the VRID using the existing device priorities. To change the priorities, you must issue the `vcs reload` command for the new priorities to take effect. For more information about the `vcs reload` command, see *Command Line Reference Guide*.

vMaster takeover can be used to assign a new vMaster without regard to existing priorities; hence it is not allowed in conjunction with VRID affinity.

## Disabling Syncing of SNMP sysContact OID

By default, the SNMP sysContact OID value is synchronized among all member ACOS devices of an aVCS virtual chassis. The current release provides an option to disable this synchronization, on an individual device basis.

**NOTE:** After configuring this option for an ACOS device, if you disable aVCS on that device, the running-config is automatically updated to continue using the same sysContact value you specified for the device. You do not need to reconfigure the sysContact on the device after disabling aVCS.

The following example shows an example; to disable syncing of SNMP contact snmp-admin on aVCS device 2:

```
ACOS(config)# no snmp-server contact snmp-admin on-device 2
```

## vMaster Maintenance Mode

---

In maintenance mode, the vMaster can briefly be placed into maintenance without triggering a failover of the vMaster role to a vBlade. During the maintenance window, the vBlades continue to operate, without attempting to failover to the vMaster role.

**NOTE:** For more information, see the `vcs vMaster-maintenance` command in the *Command Line Reference Guide*.

---

# Device Management

---

The following topics are covered:

<a href="#">Adding a Device to a Virtual Chassis</a> .....	52
<a href="#">Replacing a Device in a Virtual Chassis</a> .....	55

## Adding a Device to a Virtual Chassis

This section describes how to add a configured ACOS device to a running virtual chassis.

**CAUTION:**

By default, when you add a configured ACOS device to a running virtual chassis, the device-specific configuration is retained but the common configuration (SLB and so on) is replaced by the vMaster.

To allow the vMaster to also replace the new device's device-specific configuration, use the `disable-merge` option when you reload aVCS.

**NOTE:**

If a device has already been a member of a virtual chassis, the device can not be added to a new virtual chassis.

The following topics are covered:

<a href="#">Overview</a> .....	52
<a href="#">Procedure</a> .....	54

## Overview

---

The following [Figure 15](#) shows the process that occurs when you add an ACOS device that is already configured to a virtual chassis.

**NOTE:** The configuration merge behavior described in this section is the default behavior. If you want the vMaster to also remove the device-specific configuration information from the new device, use the `disable-merge` option when you reload aVCS.

Figure 15 : Previously Configured Device Added to Virtual Chassis and Merged with Virtual Chassis

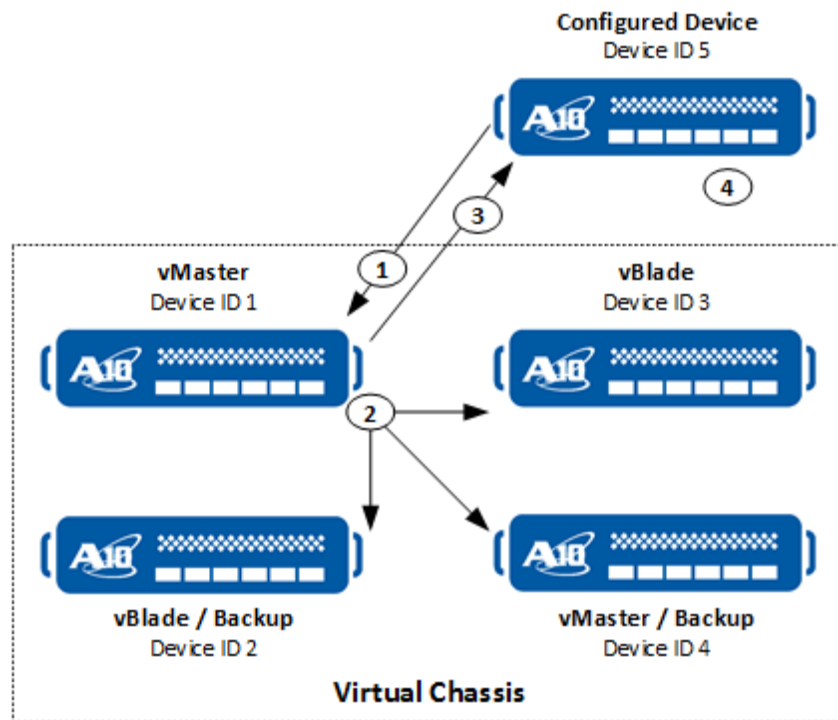

The following process occurs when you add a previously configured ACOS device to a virtual chassis:

1. The previously configured ACOS device (labeled “Configured Device” in the figure) is connected to the virtual chassis network at Layer 2.

An admin then configures aVCS settings on the previously configured device and reloads aVCS.

The VCS reload causes the device to send its aVCS configuration and its device-specific configuration to the vMaster.

2. The vMaster applies the aVCS configuration and device-specific configuration to

its virtual chassis configuration.

The vMaster then synchronizes the device's configuration to the other vBlades as part of the normal configuration synchronization process.

3. The vMaster sends its running-config to the device.
4. On the device, the vMaster running-config is saved as the device's startup-config. To complete its aVCS reload, the device loads its new startup-config. The device is now another vBlade in the virtual chassis.

## Procedure

---

To add an ACOS device that already has a configuration to an aVCS chassis:

1. Make sure the virtual chassis is running:
  - a. Log onto the floating IP address (management address) of the virtual chassis.
  - b. View the virtual chassis status using the `show vcs summary` command. For more information about the `show vcs summary` command, see *Command Line Reference Guide*.
2. Connect the configured ACOS device to the Layer 2 network that contains the other virtual chassis members.
3. Configure aVCS settings on the new device and reload aVCS.

The following commands show how to configure aVCS settings on a configured ACOS device to be added to a virtual chassis, and reload aVCS to activate the VCS configuration:

```
ACOS# configure
ACOS(config)# vrrp-a common
ACOS(config-common)# set-id 1
ACOS(config-common)# device-id 3
ACOS(config-common)# enable
ACOS-Active(config-common)# exit
ACOS-Active(config)# vcs enable
ACOS-Active(config:3)# vcs floating-ip 192.168.100.169 /24
ACOS-Active(config:3)# vcs device 3
ACOS-Active(config:3-device:3)# interface management
ACOS-Active(config:3-device:3)# priority 197
```

```
ACOS-Active(config:3-device:3)# enable
ACOS-Active(config:3-device:3)# exit
ACOS-Active(config:3)# vcs reload
```

Following the reload of aVCS, the ACOS device joins the virtual chassis as a vBlade, and its configuration information is migrated to the virtual chassis' vMaster.

4. Verify that the device is now a member of the virtual chassis using the `show vcs summary` command.

---

**NOTE:** Do not use the `disable-merge` option when you reload aVCS; this option is used only when replacing an existing virtual chassis member with a new device.

---

## Replacing a Device in a Virtual Chassis

By default, when you add an ACOS device to a virtual chassis that is already running, the device's configuration information is migrated to the vMaster.

However, if you are replacing a member of the virtual chassis by removing the ACOS device from the network and inserting another ACOS device of the same model, you may want the vMaster to migrate the removed device's configuration information to the new device. In this case, when you reload aVCS on the new device, make sure to use the `disable-merge` option:

The following commands configure aVCS settings on a replacement ACOS device to be inserted into a virtual chassis, and reload aVCS to activate the aVCS configuration:

```
ACOS# configure
ACOS(config)# vrrp-a common
ACOS(config-common)# set-id 1
ACOS(config-common)# device-id 3
ACOS(config-common)# enable
ACOS-Active(config-common)# exit
ACOS-Active(config)# vcs enable
ACOS-Active(config:3)# vcs floating-ip 192.168.100.169 /24
```

```
ACOS-Active(config:3) # vcs device 3  
ACOS-Active(config:3-device:#) # interface management  
ACOS-Active(config:3-device:3) # priority 197  
ACOS-Active(config:3-device:3) # enable  
ACOS-Active(config:3-device:3) # exit  
ACOS-Active(config:3) # vcs reload disable-merge
```

Following the reload of aVCS, the ACOS device joins the virtual chassis as a vBlade, and receives its configuration information from the virtual chassis' vMaster.

# Configuration Synchronization without Reload

---

The following topics are covered:

<a href="#">Usage Summary</a> .....	57
<a href="#">VRRP-A with aVCS Deployment Example</a> .....	59

## Usage Summary

You can use the Virtual Chassis System (aVCS) feature to provide automated configuration synchronization in VRRP-A deployments, even if you do not plan to use any other aVCS features. Use of aVCS for configuration synchronization provides the following benefits:

- aVCS configuration synchronization is automatic and occurs in real time. Each configuration change is synchronized to the other ACOS device(s) as soon as the change occurs.
- Reload is not required.

---

**NOTE:** If you activate a Capacity FlexPool license on the VCS master, it is not automatically synchronized with the VCS blade. This is because each device has a unique UUID. Therefore, you must manually activate the Capacity FlexPool license on each device in the VCS cluster.

---

[Figure 16](#) shows an example VRRP-A deployment that uses aVCS for automated configuration synchronization.

Figure 16 : aVCS Used for Automated Configuration Synchronization

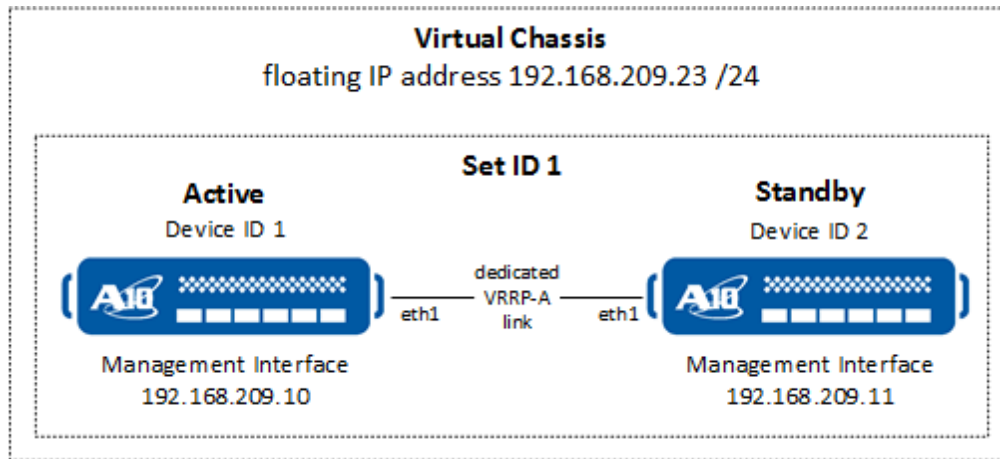

## VRRP-A with aVCS Deployment Example

The following topics are covered:

<a href="#">Commands on Device 1</a> .....	59
<a href="#">Commands on Device 2</a> .....	60

**NOTE:** The following commands deploy the VRRP-A configuration shown in [aVCS Used for Automated Configuration Synchronization](#).

### Commands on Device 1

The following commands configure the VRRP-A set ID and device ID, and enable VRRP-A on device 1:

```
ACOS-1# configure
ACOS-1(config)# vrrp-a common
ACOS-1(config-common)# set-id 1
ACOS-1(config-common)# device-id 1
ACOS-1(config-common)# enable
ACOS-1-Active(config-common)# exit
ACOS-1-Active(config)#
```

The following command enables aVCS and configures the floating IP address, which is the management address for the virtual chassis. The floating IP address must be in the same subnet as the ACOS device's management IP address or one of the device's data interface IP addresses.

```
ACOS-1-Active(config)# vcs enable
ACOS-1-Active(config:1)# vcs floating-ip 192.168.209.23 /24
```

The following commands configure the aVCS profile for the device.

```
ACOS-1-Active(config:1)# vcs device 1
ACOS-1-Active(config:1-device:1)# priority 110
ACOS-1-Active(config:1-device:1)# interface management
ACOS-1-Active(config:1-device:1)# interfaces ethernet 1
ACOS-1-Active(config:1-device:1)# enable
ACOS-1-Active(config:1-device:1)# exit
```

The **priority** command helps identify this ACOS device as the preferred vMaster. Use a higher priority value on this device than on the second device.

The **interfaces** commands identify interfaces that can be used by vVCS. It is recommended to specify more than one interface, to help ensure continued communication in case a link goes down.

The following commands save the changes and activate the VCS configuration.

```
ACOS-1-Active(config:1) # write memory  
ACOS-1-Active(config:1) # vcs reload
```

## Commands on Device 2

The following commands configure the VRRP-A set ID and device ID, and enable VRRP-A on device 2:

```
ACOS-2# configure  
ACOS-2(config) # vrrp-a common  
ACOS-2(config-common) # set-id 1  
ACOS-2(config-common) # device-id 2  
ACOS-2(config-common) # enable  
ACOS-2(config-common) # exit  
ACOS-2-Active(config) # vcs enable  
ACOS-2-Active(config:2) # vcs floating-ip 192.168.209.23 /24  
ACOS-2-Active(config:2) # vcs device 2  
ACOS-2-Active(config:2-device:2) # priority 100  
ACOS-2-Active(config:2-device:2) # interface management  
ACOS-2-Active(config:2-device:2) # interface ethernet 1  
ACOS-2-Active(config:2-device:2) # enable  
ACOS-2-Active(config:2-device:2) # exit  
ACOS-2-Active(config:2) # vcs reload
```

```
System configuration has been modified. Save? [yes/no]:yes  
Building configuration...  
Write configuration to primary default startup-config  
[OK]  
Running configuration is saved  
ACOS-2-Active(config:2) #
```

**NOTE:**

---

When you enter the `vcs reload` command on the second device, it receives non-device-specific configuration information from the first device. This occurs if the first device already has become the vMaster for the aVCS virtual chassis.

---

## Upgrading ACOS Devices with aVCS Deployment

---

aVCS can be used to upgrade software images from 4.x to 5.x or later releases. Before you begin the upgrade, it is recommended to backup the system.

The following upgrade procedures are available; choose the one that best fits your deployment.

- **Full Chassis Upgrade (with or without VRRP-A)** – This procedure upgrades the software on the vMaster for full chassis upgrade deployments with or without VRRP-A. The vMaster puts the upgrade image onto each vBlade, then reboots the vBlades to activate the new software. During the reboot, service is briefly disrupted.
- **Staggered Upgrade (with or without VRRP-A) (Recommended)** – This procedure applies to staggered upgrade deployments with or without VRRP-A. A10 recommends using staggered upgrade as it avoids disruption but has more steps to perform.

**NOTE:**

- Staggered Upgrade is not supported for upgrading ACOS 5.x cluster to ACOS 6.x cluster.
- Starting from the ACOS 6.0.0 to 6.0.5 release, the default aVCS multicast IP address has been changed from 224.0.0.210 to 224.0.1.210.

This change from 224.0.0.210 to 224.0.1.210 indicates that an intermediate switch can handle the packet differently, and aVCS communication could be interrupted. In an aVCS cluster, all devices must run the same version.

If required, the IPv4 multicast address can be changed to 224.0.0.210 by following the steps below:

```
#config
vcs multicast-ip 224.0.0.210
vcs reload
```

In the ACOS 6.0.6 release, the default aVCS multicast IP address has been changed from 224.0.1.210 to 224.0.0.211. For detailed steps, see [Upgrading aVCS Cluster from a pre-ACOS 6.0.6 Release to ACOS 6.0.6 or Later](#).

---

- **Manual Upgrade (with VRRP-A)** – This is a manual procedure to upgrade a VRRP-A ACOS device.

For more information, see the *Upgrading to ACOS 6.0.7-P2 Using aVCS* section in the Release Notes.

## Upgrading aVCS Cluster from a pre-ACOS 6.0.6 Release to ACOS 6.0.6 or Later

---

To upgrade an aVCS cluster from a pre-ACOS 6.0.6 release to ACOS 6.0.6 or later, you must perform additional steps. This is necessary due to a change in the default aVCS multicast IP address in ACOS 6.0.6 compared to previous 6.0.x releases. In previous ACOS 6.0.x releases, the default aVCS multicast IP address was 224.0.1.210. In ACOS 6.0.6 or later releases, the default multicast IP address has changed to 224.0.0.211.

### Exceptions

- If the current aVCS multicast IP is explicitly configured within the aVCS cluster, you may ignore steps 1 and 2, and proceed with the normal or staggered upgrade process. You may use the `show vcs summary` command to verify the configured multicast IP address.
- If the VCS discovery mode in the aVCS cluster is set to Unicast, you can ignore steps 1 and 2, and proceed with the normal or staggered upgrade process.

### Upgrade Steps

1. Change the multicast IP address to 224.0.0.211 by using the `vcs multicast-ip 224.0.0.211` command, followed by the `write memory` command. Ensure that the configuration is synchronized to the vBlades.

---

**NOTE:** You can use any multicast IP address of your choice, except for 224.0.1.210.

---

2. Execute the `vcs reload` command and wait for aVCS to establish successfully.
3. Continue the upgrade procedure as before, either a staggered upgrade or a normal upgrade.

The upgrade to ACOS 6.0.6 or later is completed.



©2025 A10 Networks, Inc All rights reserved. A10 Networks, the A10 Networks logo, ACOS, A10 Thunder, Thunder TPS, A10 Harmony, SSLi and SSL Insight are trademarks or registered trademarks of A10 Networks, Inc. in the United States and other countries. All other trademarks are property of their respective owners. A10 Networks assumes no responsibility for any inaccuracies in this document. A10 Networks reserves the right to change, modify, transfer, or otherwise revise this publication without notice. For the full list of trademarks, visit: [www.a10networks.com/company/legal/trademarks/](http://www.a10networks.com/company/legal/trademarks/).